

PRICE LIST

Pallet Rack
FastRak Bulk Shelving
Boltless Shelving
Cantilever Rack
Wire Shelving
Archive Shelving
Carts & Trucks
Bins & Boxes
Workbenches & Packing Tables
Stock, Reel & Tire Racks

PALLET RACK

- New and improved design.
- Deluxe 3" x 3" columns for regular and heavy duty uprights.
- Uprights feature a 5" x 8" seismic baseplate.
- Upright capacities from 16,100 to 23,300 lbs. (based upon 36" maximum shelf spacing).
- Component design allows for greater versatility with pallet rack that can be easily modified, reconfigured or entirely relocated.

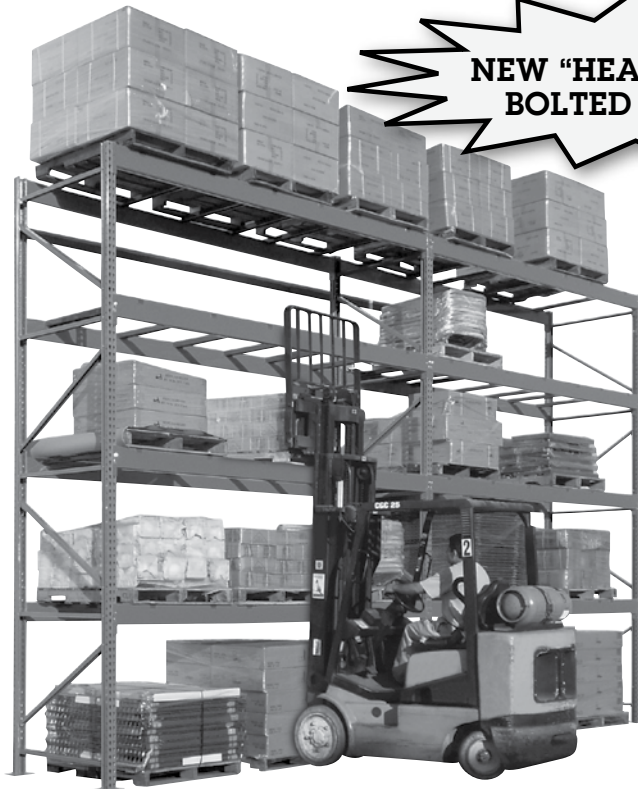

**NEW "HEAVY DUTY"
BOLTED DESIGN**

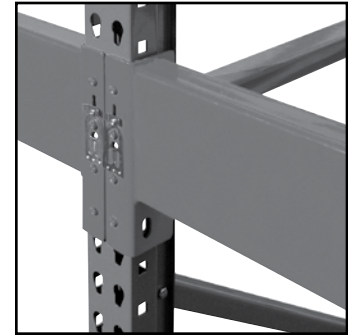

POPULAR TEAR DROP DESIGN

Interchangeable with the following pallet rack manufacturers:

Interlake (Original Style), Space Rack, USP, Lodi Metal-Tech, Steel King and Husky.

Popular tear drop design insures interchangeability with most major pallet rack manufacturers (see above list of compatible manufacturers).

UPRIGHTS

- New and improved design.
- Deluxe 3" x 3" columns for regular and heavy duty uprights.
- Uprights feature a 5" x 8" seismic base plate.
- Regular Duty Uprights feature 16 gauge steel construction and 16,100 lbs. capacity.
- Heavy Duty Uprights feature 14 gauge steel construction with a capacity of 23,300 lbs. (regular and heavy duty capacities based upon 36" maximum shelf spacing).

Regular Duty Uprights

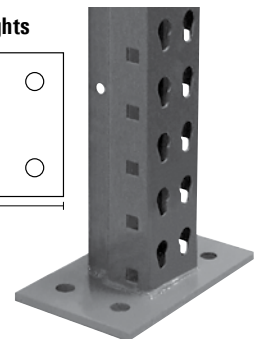
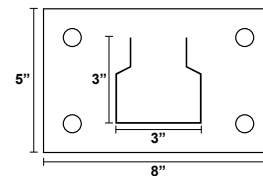

Heavy Duty Uprights

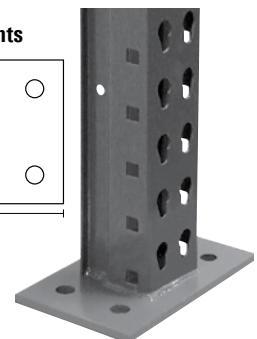
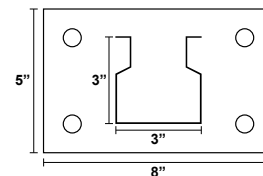

14 Gauge Heavy Duty Uprights

16 Gauge Regular Duty Uprights

MODEL NUMBER	H X D	WT.	UNASSEMBLED	ASSEMBLED
IU36096	8' x 3.0'	43	\$80.99	\$89.09
IU36120	10' x 3.0'	51	95.79	105.36
IU36144	12' x 3.0'	63	118.31	130.14
IU42096	8' x 3.5'	45	\$85.36	\$93.90
IU42120	10' x 3.5'	53	100.05	110.05
IU42144	12' x 3.5'	66	124.28	136.71
IU48096	8' x 4.0'	47	\$89.84	98.83
IU48120	10' x 4.0'	55	104.35	114.78
IU48144	12' x 4.0'	69	130.36	143.39

MODEL NUMBER	H X D	WT.	UNASSEMBLED	ASSEMBLED
IUH36120	10' x 3.0'	65	147.85	162.64
IUH36144	12' x 3.0'	80	172.28	189.51
IUH36180	15' x 3.0'	100	207.58	228.34
IUH36192	16' x 3.0'	106	221.42	243.55
IUH42120	10' x 3.5'	67	150.56	165.61
IUH42144	12' x 3.5'	83	175.32	192.86
IUH42180	15' x 3.5'	104	208.80	229.68
IUH42192	16' x 3.5'	110	222.72	245.00
IUH48120	10' x 4.0'	70	153.67	169.04
IUH48144	12' x 4.0'	86	178.76	196.64
IUH48180	15' x 4.0'	109	216.14	237.75
IUH48192	16' x 4.0'	114	230.55	253.61

STEP LOAD BEAMS

- Two beams required to create a shelf.
- Beams feature a replaceable safety clip which helps prevent the beam from detaching from the upright.
- Interchangeable with most major pallet rack manufacturers.
- Beam capacities are based on a evenly distributed load and have a 1.65 safety factor.

3-Pin Connector

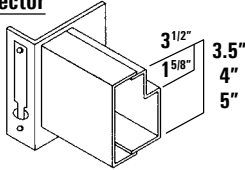

MODEL NUMBER	H X L	CAP. PER PAIR	WT.	PRICE
REGULAR DUTY				
215-IB35096	3.5" x 8'	3,460	25.1	48.10
215-IB40096	4.0" x 8'	4,977	28.9	52.18
215-IB40108	4.0" x 9'	4,228	32.0	58.07
215-IB40120	4.0" x 10'	3,425	34.0	64.00

4-Pin Connector

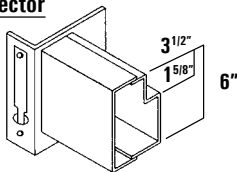

MODEL NUMBER	H X L	CAP. PER PAIR	WT.	PRICE
HEAVY DUTY				
215-IB50096	5.0" x 8'	7,035	32.8	59.76
215-IB50108	5.0" x 9'	7,103	37.4	66.61
215-IB50120	5.0" x 10'	6,004	41.5	73.44
215-IB50144	5.0" x 12'	4,170	48.3	87.10
215-IB60144	6.0" x 12'	6,511	51.5	110.10

WIRE MESH DECKING

- 2 1/4" x 4 1/4" Wire Spacing.
- Constructed of 4 gauge wire and 13 gauge flared channels.
- Features a durable zinc electrogalvanized finish.

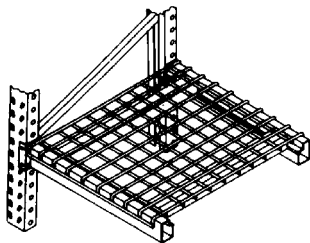

MODEL NUMBER	D X W	WEIGHT	CAPACITY	PRICE
ORDER BY PIECE				
215-DF3646	36" x 46"	19.0	2,500	33.91
215-DF3658	36" x 58"	22.0	2,300	39.53
215-DF4246	42" x 46"	21.6	2,100	38.13
215-DF4258	42" x 58"	27.9	2,200	49.22
215-DF4846	48" x 46"	25.0	1,800	44.63
215-DF4858	48" x 58"	32.5	2,100	59.06

STEEL SAFETY SUPPORTS

- Use as front to back member to support pallets or wood decking.
- Can be used in conjunction with wood decking to provide additional support for hand stacking applications.

MODEL NUMBER	UPRIGHT DEPTH	WEIGHT	PRICE
STEEL			
215-USS36	3.0'	5.0	11.97
215-USS42	3.5'	5.9	13.86
215-USS48	4.0'	6.7	15.16

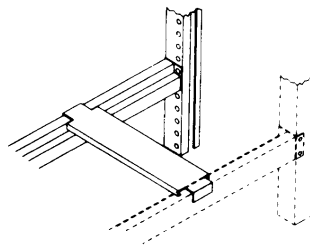

ROW SPACERS

- Used to connect rows of pallet rack (back to back).
- Spacers increase stability and maintain consistent spacing between rows.

MODEL NUMBER	ROW SPACE	WEIGHT	PRICE
215-IR06	6"	0.9	6.11
215-IR12	12"	1.5	9.23
215-IR18	18"	2.2	12.36

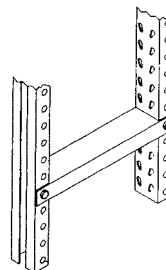

BAY DIVIDERS

- Organize material vertically with dividers.
- Designed to fit over our step load beams.
- Easy to install; no hardware required.
- Pre-punched holes for permanent mounting.



MODEL #	WT.	PRICE
215-ID01	10.4	87.69

FRAME GUARDS

- Avoid damage to valuable rack columns.
- Solid steel guards withstand impacts with heavy duty construction.
- Features high visibility yellow powder coat finish and 4 mounting holes.



MODEL #	GUARD HEIGHT	WT.	PRICE
215-ICP24	24"	10.0	33.97

LABEL HOLDERS

- Extra large for Pallet Rack applications.
- Self Adhesive or Magnetic label holder allows for simple label relocation.
- Includes Ink Jet/Laser compatible white inserts with instructions.



MODEL #	DESCRIPTION	QTY	PRICE
215-L335	3" x 5" - Self Adhesive	50	61.82
215-L346	4" x 6" - Self Adhesive	50	73.71
215-L335M	3" x 5" - Magnetic	50	85.60
215-L346M	4" x 6" - Magnetic	50	107.00

FASTRAK HEAVY DUTY BULK SHELVING

- Ideal alternative to Pallet Rack for hand stacking.
- Newly designed knockdown upright that allows easier shipment and component replacement.
- Tear drop design lets beams lock securely into uprights.
- Built-in safety clip for additional safety.
- Available with Wire Mesh or 3/4" Particle Board decking.



FASTRAK COMPONENTS

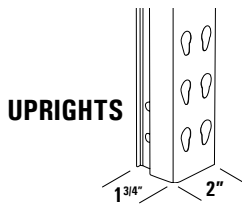

- Heavy duty bolted FastRak design.
- Design allows for easier shipment.
- Uprights allow adjustment of shelf height every 1 1/2".
- 7,000 lb. capacity per upright.
- Foot plates optional.

STEP LOAD BEAMS

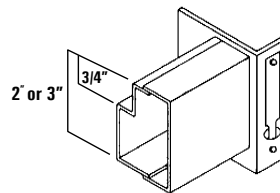

- Available in either 2" or 3" beam height.
- Available 24", 36", 48", 72" or 96" in length.
- Built-in safety clip.

MODEL NUMBER	D X H	WEIGHT	UNASSEMBLED	ASSEMBLED
CU18072	18" x 72"	22	42.67	46.94
CU18096	18" x 96"	28	52.24	57.46
CU18120	18" x 120"	35	65.22	71.74
CU24072	24" x 72"	24	45.44	49.98
CU24096	24" x 96"	30	54.97	60.47
CU24120	24" x 120"	37	67.89	74.68
CU36036	36" x 36"	15	44.58	49.04
CU36072	36" x 72"	27	54.12	59.53
CU36096	36" x 96"	33	63.65	70.02
CU36120	36" x 120"	42	73.18	80.50
CU48036	48" x 36"	17	53.25	58.58
CU48072	48" x 72"	31	62.80	69.08
CU48096	48" x 96"	37	72.34	79.57
CU48120	48" x 120"	47	81.87	90.06

MODEL #	H X L	WT.	CAP. PER PAIR	PRICE
215-CB20048	2" x 48"	9.3	1,400	14.16
215-CB20072	2" x 72"	9.5	1,200	20.36
215-CB20096	2" x 96"	12.5	1,000	26.57
215-CBL30024	3" x 24"	5.1	2,000	8.16
215-CBL30036	3" x 36"	5.1	2,000	11.80
215-CB30048	3" x 48"	11.7	2,000	17.44
215-CB30072	3" x 72"	15.3	1,800	25.28
215-CB30096	3" x 96"	16.5	1,600	33.14

WIRE MESH DECKING

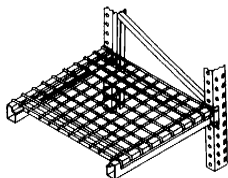

- Improves visibility and sprinkler effectiveness.
- Built-in supports.
- Wire decks sold per piece.

MODEL #	D X L	WT.	PRICE
215-CW1835	18" x 35"	6.3	23.96
215-CW1847	18" x 47"	7.8	25.78
215-CW2435	24" x 35"	8.2	26.02
215-CW2447	24" x 47"	10.0	28.17
215-CW3635	36" x 35"	12.1	30.20
215-CW3647	36" x 47"	14.8	32.97
215-CW4835	48" x 35"	16.0	33.84
215-CW4847	48" x 47"	19.4	37.99

SAFETY SUPPORTS

- Use in conjunction with particle board to maximize shelf capacity.
- Supports fit in notches in beams to maintain level shelf surface.

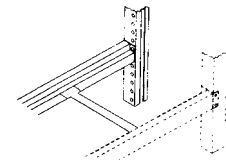

MODEL #	LENGTH	WT.	PRICE
215-CSS24	24"	2.2	3.08
215-CSS36	36"	2.5	4.61
215-CSS48	48"	2.8	6.08

PARTICLE BOARD



- 3/4" Particle Board Decking.
- Cut to fit inside beams.

MODEL #	D X L	WT.	PRICE
240-044818	18" x 48"	16.9	10.49
240-047218	18" x 72"	25.3	15.72
240-049618	18" x 96"	33.8	20.97
240-044824	24" x 48"	22.5	13.97
240-047224	24" x 72"	33.8	20.97
240-049624	24" x 96"	45.0	27.96
240-044836	36" x 48"	33.8	20.97
240-047236	36" x 72"	50.6	31.45
240-049636	36" x 96"	67.5	41.93
240-044848	48" x 48"	45.0	27.96
240-047248	48" x 72"	67.5	41.93
240-049648	48" x 96"	90.0	55.91

DELUXE FOOT PLATES

- Optional foot plates easily bolts into upright.
- Foot plates allow FastRak to be anchored into concrete for additional safety or permanent placement.
- Concrete wedge anchors sold separately.

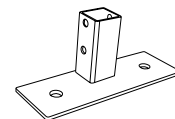

MODEL #	WT.	PRICE
DELUXE FOOT PLATE		
CUCF01	1.0	\$3.08
CONCRETE WEDGE ANCHOR		
235-FA01	0.1	\$1.07

LABEL HOLDERS

- Extra large labels.
- Self-Adhesive or Magnetic.
- Bar code compatible.



MODEL #	SIZE	QTY	PRICE
ADHESIVE			
215-L335	3" x 5"	50	\$61.82
MAGNETIC			
215-L335M	3" x 5"	50	\$85.60

MEDIUM DUTY CANTILEVER RACK

- Ideal for storing long products such as bars, pipes and rods.
- Available as either a single or double sided units.
- All units are 79" tall.
- Arms are adjustable in 1 1/2" increments.
- Choose from either 12", 18" or 24" arms.
- Angled arms and welded end-stops provide secure/safe storage of long and/or irregular shaped merchandise.

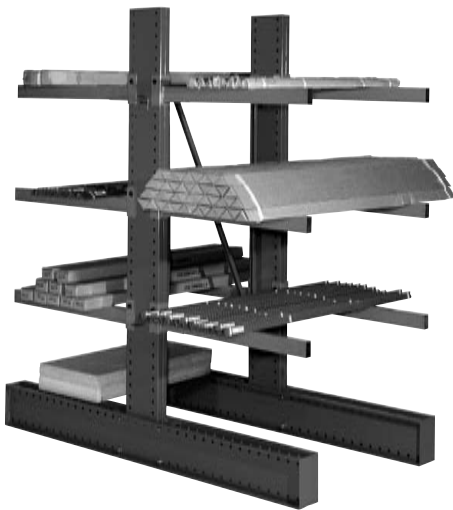

HOW TO ORDER

A. Select Arm

1. Choose Arm Length
2. Choose either Regular Duty or Heavy Duty based on arm angle and capacity required

B. Select Base/Column Size

1. Choose either single sided or double sided base
2. Choose Column height
 - a. When column serve as load stops. it is necessary to specify column heights greater than the top loading arms. There is no need to pay for extra column height unless load stops are desired or future expansion is anticipated.
 - b. Arm height adjustable in 3" increment
 - c. Select appropriate base for arms selected in "A" above

C. Select Brace Set

***Heavy Duty Arm End-Stops**

MODEL #	ARM ANGLE	WT.	PRICE
CHAHS01	4°	1.5	\$8.72
CHAHS02	20°	1.5	8.72

*End-Stops are for use with heavy duty arms only

Brace Beams			
MODEL NUMBER	WIDTH	WEIGHT	PRICE
215-CBL30036	36"	6	\$12.63
215-CB30048	48"	9	17.44
215-CB30072	72"	12	25.28

Arms w/ Connecting Bolt				
MODEL #	CAP.	LENGTH	WEIGHT	PRICE
215-GA12	1,000	12"	5.5	\$15.50
215-GA18	800	18"	18	20.16
215-GA24	600	24"		27.29

Columns			
MODEL NUMBER	LENGTH	WEIGHT	PRICE
SINGLE SIDED COLUMNS			
215-GCS08012	12" Single Sided	40	\$163.65
215-GCS08018	18" Single Sided	41	180.00
215-GCS08024	24" Single Sided	45	215.98
DOUBLE SIDED COLUMNS			
215-GCD08012	12" Double Sided	45	\$184.96
215-GCD08018	18" Double Sided	52	203.46
215-GCD08024	24" Double Sided	56	244.15

HEAVY DUTY CANTILEVER RACK

- The ideal heavy duty tube, bar stock and long material storage.
- Available with either single sided or double sided base.
- Columns are available in 8', 10' or 12' high.
- Arms are available in 4° or 20° angles and 24", 36" or 48" lengths.
- Purchase arm end-stops separately to provide secure and safe storage of long and/or irregular shaped merchandise.

Regular Duty Arms				
MODEL #	LENGTH	CAP. PER ARM	WT.	PRICE
4° ARMS				
215-HA24	24"	1,800	16	\$30.99
215-HA36	36"	1,200	17	39.12
215-HA48	48"	900	20	47.26

Heavy Duty Arms				
MODEL #	LENGTH	CAP. PER ARM	WT.	PRICE
4° ARMS				
215-HAH36	36"	2,050	27	\$60.98
215-HAH48	48"	1,600	32	73.42
20° ARMS				
215-HBH24	24"	2,200	15	\$50.25
215-HBH36	36"	2,050	20	67.08
215-HBH48	48"	1,600	24	80.76

Brace Sets			
MODEL #	WIDTH	WT.	PRICE
BRACE SETS FOR 8' & 10' HIGH			
215-HXP36	3'	22	\$46.41
215-HXP48	4'	26	55.78
215-HXP72	6'	35	75.31
215-HXP96	8'	50	95.40

Brace Sets for 12' High			
MODEL #	WIDTH	WT.	PRICE
CHX-36	3'	28	\$56.75
CHX-48	4'	34	70.00
CHX-72	6'	46	97.30
CHX-96	8'	66	125.14

Single Sided Base / Column				
MODEL #	HEIGHT	CAP. PER COLUMN	WT	PRICE
24" ARM				
CHS-09624	8'	11,200	173	\$419.19
CHS-12024	10'	11,200	199	480.42
CHS-14424	12'	11,200	244	541.64
36" ARM				
CHS-09636	8'	8,400	185	\$449.94
CHS-12036	10'	8,400	211	511.15
CHS-14436	12'	8,400	236	572.39
48" ARM				
CHS-09648	8'	6,700	199	\$480.67
CHS-12048	10'	6,700	224	541.90
CHS-14448	12'	6,700	249	603.12

Double Sided Base / Column				
MODEL #	HEIGHT	CAP. PER COLUMN	WT.	PRICE
24" ARM				
CHD-09624	8'	22,400	197	\$510.91
CHD-12024	10'	22,400	222	572.13
CHD-14424	12'	22,400	248	633.35
36" ARM				
CHD-09636	8'	16,800	222	\$572.89
CHD-12036	10'	16,800	248	634.11
CHD-14436	12'	16,800	273	695.34
48" ARM				
CHD-09648	8'	13,400	248	\$621.39
CHD-12048	10'	13,400	273	682.62
CHD-14448	12'	13,400	298	743.83

UPRIGHT POSTS

- 14 gauge construction.
- 1^{1/2}" x 1^{1/2}" regular duty post.
- 1^{7/8}" x 1^{7/8}" heavy duty post.



Regular Duty

MODEL NUMBER	HEIGHT	WEIGHT	PRICE
200-P2.5	2.5'	1.5	3.63
200-P3	3.0'	1.7	4.35
200-P4	4.0'	2.0	5.82
200-P5	5.0'	2.5	7.28
200-P6	6.0'	3.0	8.72
200-P7	7.0'	4.0	10.17
200-P8	8.0'	4.4	11.63
200-P9	9.0'	5.0	13.09
200-P10	10.0'	5.5	14.54
200-P12	12.0'	6.5	17.45

Heavy Duty

MODEL NUMBER	HEIGHT	WEIGHT	PRICE
200-PH7	7'	5.7	12.20
200-PH8	8'	6.0	13.95
200-PH10	10'	7.9	17.45
200-PH12	12'	9.1	20.92

SINGLE RIVET BEAM

- Regular Duty - 14 gauge.
- Heavy Duty - 11 gauge.
- 1" height.
- Use as a left to right or front to back.



Regular Duty

MODEL NUMBER	LENGTH	WEIGHT	PRICE
200-SR12	12"	0.5	1.24
200-SR18	18"	0.7	1.80
200-SR24	24"	0.9	2.20
200-SR30	30"	1.2	2.86
200-SR36	36"	1.4	3.15
200-SR42	42"	1.6	3.71
200-SR48	48"	1.8	3.93

Heavy Duty

MODEL NUMBER	LENGTH	WEIGHT	PRICE
200-SRH36	36"	2.4	5.55
200-SRH48	48"	3.2	7.30
200-SRH60	60"	4.1	8.82

TIE PLATE

- Use to connect units side by side in rows.



MODEL NUMBER	WT.	PRICE
200-TP	0.2	\$0.91

FOOTPLATES

- Use to anchor units to the ground.



MODEL NUMBER	WT.	PRICE
200-FPD (Double)	0.4	\$2.33
200-FPR (Right)	0.2	1.78
200-FPL (Left)	0.2	1.78

DOUBLE RIVET BEAM

- 16 gauge construction; 14 gauge on 60" beams and larger.
- 2^{3/4}" height.
- Use as a left to right or front to back.



MODEL NUMBER	LENGTH	WEIGHT	PRICE
200-DR12	12"	0.7	1.97
200-DR15	15"	0.8	2.25
200-DR18	18"	1.0	2.62
200-DR24	24"	1.5	3.26
200-DR30	30"	1.8	4.02
200-DR36	36"	2.0	4.76
200-DR42	42"	2.3	5.47
200-DR48	48"	2.7	6.18
200-DR60	60"	4.0	8.45
200-DR69	69"	4.5	9.98
200-DR72	72"	4.6	9.98
200-DR84	84"	5.5	11.66
200-DR96	96"	6.0	13.17

DOUBLE RIVET CHANNEL BEAM

- Regular Duty - 14 gauge.
- Heavy Duty - 11 gauge.
- 2^{3/4}" height.
- Use as a left to right for greater shelf capacity.



Regular Duty

MODEL NUMBER	LENGTH	WEIGHT	PRICE
200-DC72	72"	5.5	\$13.11
200-DC96	96"	7.5	17.47

Heavy Duty

MODEL NUMBER	LENGTH	WEIGHT	PRICE
200-DCH72	72"	9.0	18.96
200-DCH96	96"	12.5	25.51

SHELF DECK SUPPORT

- 16 gauge construction.
- 2^{1/2}" height.
- Adds capacity to shelf when bolted between double rivet beams or double rivet channel beams.



MODEL NUMBER	LENGTH	WEIGHT	PRICE
200-SDS12	12"	0.7	3.40
200-SDS15	15"	0.8	3.54
200-SDS18	18"	1.0	3.67
200-SDS24	24"	1.3	4.41
200-SDS30	30"	1.6	4.88
200-SDS36	36"	1.9	5.52
200-SDS48	48"	2.5	7.10

SHELVING LABEL HOLDERS

- Durable clear plastic will not crack, peel, fade or fall off.
- Insert paper may be reversed, remarked and re-inserted when changes are required.
- Laser / Jet Inkjet paper inserts included.

Self Adhesive

MODEL NUMBER	SIZE	QTY	PRICE
200-L231	3/4" x 6"	12	\$24.57
200-L211	1" x 6"	12	29.18
200-L251	2" x 6"	12	37.32



Magnetic

MODEL NUMBER	SIZE	QTY	PRICE
200-M211	1" x 6"	12	\$30.23
200-M261	2 1/2" x 6"	12	60.03

WALL TIE

- Secure boltless shelving units to wall.
- Provides 9" of space between wall and units.



MODEL NUMBER	WEIGHT	PRICE
200-WT09	7.7	\$3.42

PARTICLE BOARD DECKING

- Particle board decking provides a strong and durable shelf surface.
- 1/2" particle board decking is recommended for standard to light duty applications.
- 3/4" thick particle board is idea for heavy duty applications.



1/2" Particle Board			3/4" Particle Board	
SIZE W X D	MODEL NUMBER	PRICE	MODEL NUMBER	PRICE
36" x 12"	240-013612	3.75	240-023612	5.23
36" x 18"	240-013618	5.62	240-023618	7.86
36" x 24"	240-013624	7.49	240-023624	10.49
36" x 36"	240-013636	11.24	240-023636	15.72
42" x 15"	240-014215	5.47	240-024215	7.65
42" x 30"	240-014230	10.91	240-024230	15.29
48" x 12"	240-014812	5.00	240-024812	6.99
48" x 18"	240-014818	7.49	240-024818	10.49
48" x 24"	240-014824	9.98	240-024824	13.97
48" x 30"	240-014830	12.48	240-024830	17.47
48" x 36"	240-014836	14.98	240-024836	20.97
48" x 42"	240-014842	17.47	240-024842	24.46
48" x 48"	240-014848	19.97	240-024848	27.96
60" x 12"	240-016012	6.24	240-026012	8.73
60" x 18"	240-016018	9.33	240-026018	13.11
60" x 24"	240-016024	12.48	240-026024	17.47
60" x 30"	240-016030	15.60	240-026030	21.85
60" x 36"	240-016036	18.71	240-026036	26.20
60" x 42"	240-016042	21.85	240-026042	30.58
60" x 48"	240-016048	24.96	240-026048	34.95

MOBILE SHELF CART BASES

- Constructed from heavy duty steel.
- Cart bases are available with 5" or 6" casters (2 rigid and 2 swivel)
- Capacity: 700 lbs. per base.



MODEL NUMBER	SIZE L X W	WEIGHT	PRICE
--------------	------------	--------	-------

5" CASTERS

MCKA5-3612	36" x 12"	19	\$99.81
MCKA5-3618	36" x 18"	19	111.30
MCKA5-3624	36" x 24"	21	125.19
MCKA5-4812	48" x 12"	19	109.94
MCKA5-4818	48" x 18"	20	120.80
MCKA5-4824	48" x 24"	22	130.99
MCKA5-4836	48" x 36"	26	156.17
MCKA5-6018	60" x 18"	22	130.31
MCKA5-6024	60" x 24"	24	145.99
MCKA5-6030	60" x 30"	25	152.10
MCKA5-6036	60" x 36"	27	162.96

6" CASTERS

MCKA6-3612	36" x 12"	23	\$150.56
MCKA6-3618	36" x 18"	23	162.04
MCKA6-3624	36" x 24"	25	175.93
MCKA6-4812	48" x 12"	23	160.68
MCKA6-4818	48" x 18"	24	171.54
MCKA6-4824	48" x 24"	26	181.73
MCKA6-4836	48" x 36"	30	206.91
MCKA6-6018	60" x 18"	26	181.05
MCKA6-6024	60" x 24"	28	196.73
MCKA6-6030	60" x 30"	29	202.84
MCKA6-6036	60" x 36"	31	213.70



**Additional
Heights
Available!**

SERIES 200B UNITS

- No nuts, bolts or shelf clips.
- 14 gauge posts.
- Accessible from all four sides.
- Shelves are adjustable every 1^{1/2}".
- Available with or without particle board decking.

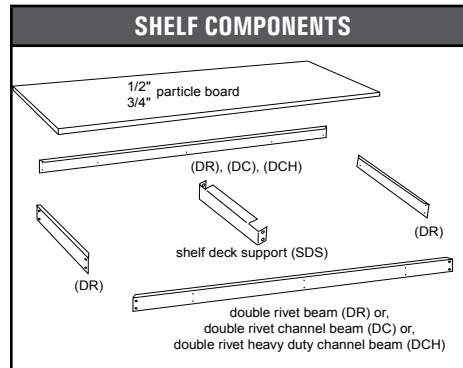

SERIES 200B SHELF ILLUSTRATION

Advanced Boltless Design



MODEL NUMBER CODE: B3-7218-84WHCR

- Series 200B _____
- Number of Shelves _____
- Shelf Width in Inches _____
- Shelf Depth in Inches _____
- Unit Height in Inches _____
- Particle Board Decking Included _____
- Shelf Deck Support Included (1 per Shelf) _____
- Channel Beam _____
- Heavy Duty Channel Beam,
1^{7/8}" x 1^{7/8}" Heavy Duty Post,
3/4" Particle Board Decking _____

		3 Shelf Unit				Extra Shelf				3 Shelf Unit				Extra Shelf																																																																																																																																																																																																																																																																									
W X D	SHELF CAP.	MODEL NUMBER	WT.	PRICE	MODEL NUMBER	WT.	PRICE	MODEL NUMBER	WT.	PRICE	MODEL NUMBER	WT.	PRICE	MODEL NUMBER	WT.	PRICE																																																																																																																																																																																																																																																																							
WITH PARTICLE BOARD DECKING								WITHOUT PARTICLE BOARD DECKING																																																																																																																																																																																																																																																																															
4' WIDE UNITS																																																																																																																																																																																																																																																																																							
48" x 18"	1,000	B3-4818-84W	90	115.93	BX1-4818-W	23	25.09	B3-4818-84	50	93.46	BX1-4818	9	17.60	48" x 24"	1,000	B3-4824-84W	107	127.31	BX1-4824-W	28	28.88	B3-4824-84	43	97.36	BX1-4824	9	18.90	48" x 30"	1,000	B3-4830-84W	124	139.29	BX1-4830-W	34	32.87	B3-4830-84	44	101.85	BX1-4830	10	20.38	48" x 36"	1,000	B3-4836-84WH	141	167.74	BX1-4836-WH	35	42.36	B3-4836-84H	53	122.83	BX1-4836-H	11	27.38	48" x 48"	1,000	B3-4848-84WH	184	196.01	BX1-4848-WH	50	51.78	B3-4848-84H	60	136.11	BX1-4848-H	16	31.80																																																																																																																																																																																																																		
5' WIDE UNITS																																																																																																																																																																																																																																																																																							
60" x 18"	750	B3-6018-84W	111	135.26	BX1-6018-W	30	31.52	B3-6018-84	51	107.16	BX1-6018	13	22.16	60" x 18"	1,200	B3-6018-84WH	112	146.26	BX1-6018-WH	31	35.19	B3-6018-84H	52	118.18	BX1-6018-H	14	25.83	60" x 24"	750	B3-6024-84W	132	148.51	BX1-6024-W	37	35.94	B3-6024-84	52	111.07	BX1-6024	14	23.47	60" x 24"	1,200	B3-6024-84WH	133	161.72	BX1-6024-WH	39	40.34	B3-6024-84H	53	124.28	BX1-6024-H	15	27.86	60" x 30"	750	B3-6030-84W	152	162.07	BX1-6030-W	44	40.56	B3-6030-84	52	115.56	BX1-6030	14	24.96	60" x 30"	1,200	B3-6030-84WH	154	177.00	BX1-6030-WH	46	45.44	B3-6030-84H	54	130.20	BX1-6030-H	16	29.83	60" x 36"	750	B3-6036-84W	173	176.13	BX1-6036-W	51	45.14	B3-6036-84	53	119.98	BX1-6036	15	26.43	60" x 36"	1,200	B3-6036-84WH	176	192.69	BX1-6036-WH	53	50.66	B3-6036-84H	56	136.53	BX1-6036-H	17	31.95	60" x 48"	750	B3-6048-84W	214	203.40	BX1-6048-W	64	54.24	B3-6048-84	55	128.52	BX1-6048	16	29.28	60" x 48"	1,200	B3-6048-84WH	218	224.69	BX1-6048-WH	67	61.33	B3-6048-84H	58	149.81	BX1-6048-H	20	36.38																																																																																																																																												
6' WIDE UNITS																																																																																																																																																																																																																																																																																							
72" x 18"	600	B3-7218-84W	126	149.99	BX1-7218-W	36	36.43	B3-7218-84	54	116.30	BX1-7218	15	25.20	72" x 18"	1,200	B3-7218-84WH	127	161.00	BX1-7218-WH	37	40.11	B3-7218-84H	55	127.31	BX1-7218-H	16	28.88	72" x 18"	1,500	B3-7218-84WHC	129	179.73	BX1-7218-WHC	38	46.35	B3-7218-84HC	57	146.03	BX1-7218-HC	18	35.12	72" x 18"	2,000	B3-7218-84WHR	171	236.53	BX1-7218-WHR	50	62.57	B3-7218-84HR	30	189.36	BX1-7218-HR	23	46.86	72" x 24"	600	B3-7224-84W	151	165.12	BX1-7224-W	44	41.48	B3-7224-84	55	120.20	BX1-7224	16	26.51	72" x 24"	1,200	B3-7224-84WH	152	178.34	BX1-7224-WH	45	45.88	B3-7224-84H	56	133.42	BX1-7224-H	17	30.91	72" x 24"	1,500	B3-7224-84WHC	154	197.06	BX1-7224-WHC	47	52.12	B3-7224-84HC	59	152.13	BX1-7224-HC	19	37.15	72" x 24"	2,000	B3-7224-84WHR	201	258.36	BX1-7224-WHR	60	69.85	B3-7224-84HR	93	195.46	BX1-7224-HR	24	48.88	72" x 30"	600	B3-7230-84W	175	180.85	BX1-7230-W	52	46.73	B3-7230-84	55	124.69	BX1-7230	16	28.00	72" x 30"	1,200	B3-7230-84WH	177	195.50	BX1-7230-WH	53	51.60	B3-7230-84H	57	139.34	BX1-7230-H	18	32.88	72" x 30"	1,500	B3-7230-84WHC	179	214.21	BX1-7230-WHC	55	57.83	B3-7230-84HC	60	158.06	BX1-7230-HC	20	39.12	72" x 30"	2,000	B3-7230-84WHR	231	280.01	BX1-7230-WHR	70	77.06	B3-7230-84HR	96	201.38	BX1-7230-HR	25	50.85	72" x 36"	600	B3-7236-84W	197	196.49	BX1-7236-W	60	51.94	B3-7236-84	56	129.11	BX1-7236	17	29.47	72" x 36"	1,200	B3-7236-84WH	203	213.05	BX1-7236-WH	62	57.45	B3-7236-84H	59	145.66	BX1-7236-H	18	34.99	72" x 36"	1,500	B3-7236-84WHC	205	231.76	BX1-7236-WHC	64	63.69	B3-7236-84HC	61	164.37	BX1-7236-HC	21	41.23	72" x 36"	2,000	B3-7236-84WHR	261	299.56	BX1-7236-WHR	80	84.40	B3-7236-84HR	99	207.71	BX1-7236-HR	26	52.97	72" x 48"	600	B3-7248-84W	249	227.50	BX1-7248-W	76	62.27	B3-7248-84	58	137.64	BX1-7248	19	32.31	72" x 48"	1,200	B3-7248-84WH	253	248.81	BX1-7248-WH	79	69.37	B3-7248-84H	61	158.96	BX1-7248-H	22	39.42	72" x 48"	1,500	B3-7248-84WHC	255	267.52	BX1-7248-WHC	80	75.61	B3-7248-84HC	63	177.67	BX1-7248-HC	23	45.66	72" x 48"	2,000	B3-7248-84WHR	321	346.79	BX1-7248-WHR	100	99.32	B3-7248-84HR	105	221.00	BX1-7248-HR	28	57.39
7' WIDE UNITS																																																																																																																																																																																																																																																																																							
84" x 18"	600	B3-8418-84WH	131	\$176.73	BX1-8418-WH	38	\$45.35	B3-8418-84H	62	\$137.42	BX1-8418-H	15	\$32.25	84" x 24"	600	B3-8424-84WH	157	195.94	BX1-8424-WH	47	51.75	B3-8424-84H	65	143.53	BX1-8424-H	16	34.28	84" x 30"	600	B3-8430-84WH	183	214.96	BX1-8430-WH	56	58.09	B3-8430-84H	68	149.44	BX1-8430-H	17	36.25	84" x 36"	600	B3-8436-84WH	209	267.52	BX1-8436-WH	64	64.56	B3-8436-84H	71	155.77	BX1-8436-H	18	38.36	84" x 48"	600	B3-8448-84WH	262	346.79	BX1-8448-WH	82	77.74	B3-8448-84H	77	169.06	BX1-8448-H	20	42.79																																																																																																																																																																																																																		
8' WIDE UNITS																																																																																																																																																																																																																																																																																							
96" x 18"	600	B3-9618-84WH	157	\$191.33	BX1-9618-WH	48	\$50.23	B3-9618-84H	60	\$160.43	BX1-9618-H	20	\$35.25	96" x 18"	1,000	B3-9618-84WHC	160	217.17	BX1-9618-WHC	50	58.83	B3-9618-84HC	64	186.02	BX1-9618-HC	23	43.85	96" x 18"	1,500	B3-9618-84WHR	217	291.49	BX1-9618-WHR	65	80.89	B3-9618-84HR	109	246.88	BX1-9618-HR	29	59.92	96" x 24"	600	B3-9624-84WH	190	212.41	BX1-9624-WH	59	57.35	B3-9624-84H	61	164.71	BX1-9624-H	21	37.28	96" x 24"	1,000	B3-9624-84WHC	193	238.24	BX1-9624-WHC	61	65.85	B3-9624-84HC	65	192.61	BX1-9624-HC	24	45.88	96" x 24"	1,500	B3-9624-84WHR	256	318.56	BX1-9624-WHR	78	89.91	B3-9624-84HR	112	253.47	BX1-9624-HR	30	61.96	96" x 30"	600	B3-9630-84WH	223	233.30	BX1-9630-WH	70	64.20	B3-9630-84H	62	171.10	BX1-9630-H	22	39.25	96" x 30"	1,000	B3-9630-84WHC	226	259.14	BX1-9630-WHC	72	72.81	B3-9630-84HC	66	199.00	BX1-9630-HC	25	47.85	96" x 30"	1,500	B3-9630-84WHR	295	345.45	BX1-9630-WHR	91	98.88	B3-9630-84HR	115	259.87	BX1-9630-HR	31	63.93	96" x 36"	600	B3-9636-84WH	256	254.61	BX1-9636-WH	80	71.30	B3-9636-84H	64	177.93	BX1-9636-H	22	41.36	96" x 36"	1,000	B3-9636-84WHC	260	280.44	BX1-9636-WHC	83	79.92	B3-9636-84HC	67	205.84	BX1-9636-HC	26	49.97	96" x 36"	1,500	B3-9636-84WHR	334	372.73	BX1-9636-WHR	104	107.97	B3-9636-84HR	118	266.71	BX1-9636-HR	32	66.04	96" x 48"	600	B3-9648-84WH	323	297.85	BX1-9648-WH	102	85.73	B3-9648-84H	66	192.29	BX1-9648-H	26	45.79	96" x 48"	1,000	B3-9648-84WHC	326	323.69	BX1-9648-WHC	104	94.33	B3-9648-84HC	70	220.19	BX1-9648-HC	28	54.40	96" x 48"	1,500	B3-9648-84WHR	412	427.96	BX1-9648-WHR	130	126.38	B3-9648-84HR	124	281.05	BX1-9648-HR	34	70.47																																																																						



SERIES 200A UNITS

- No nuts, bolts or shelf clips.
- 14 gauge posts.
- Heavy duty construction.
- Accessible from all four sides.
- Shelves are adjustable every 1 1/2".
- Available with or without particle board decking.

Additional Heights Available!

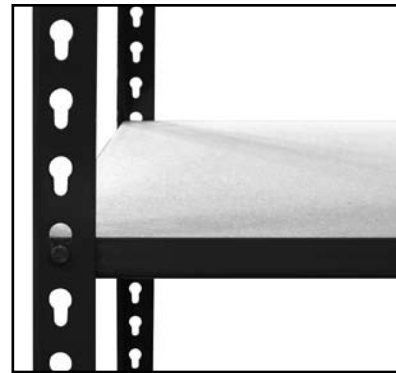

Advanced boltless design which provides easy assembly without nuts, bolts or shelf clips.

SERIES 200A SHELF ILLUSTRATION

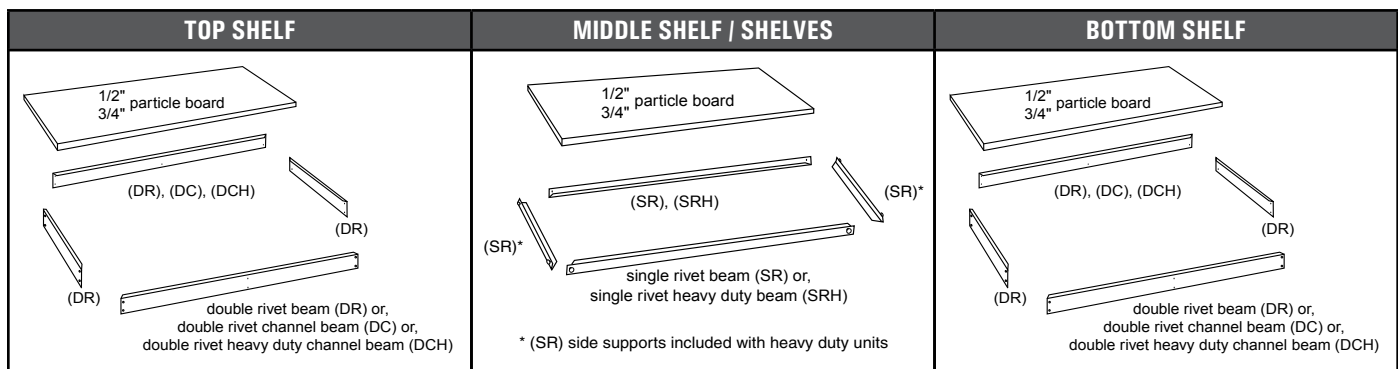

MODEL NUMBER CODE: AH7-4824-84W

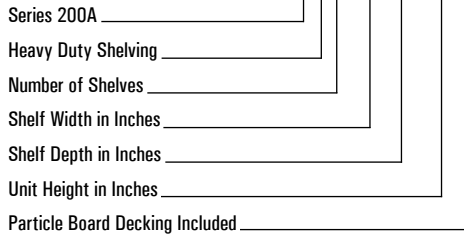

With Particle Board Decking

Without Particle Board Decking

W X D	MODEL #	WT.	CAP.	PRICE	MODEL #	WT.	CAP.	PRICE	MODEL #	WT.	CAP.	PRICE	MODEL #	WT.	CAP.	PRICE
REGULAR DUTY				HEAVY DUTY				REGULAR DUTY				HEAVY DUTY				
4-SHELF UNITS																
36" x 12"	A4-3612-84W	62	300	95.14	AH4-3612-84W	77	500	115.71	A4-3612-84	34	300	80.18	AH4-3612-84	41	500	94.74
36" x 18"	A4-3618-84W	75	300	105.22	AH4-3618-84W	97	500	131.03	A4-3618-84	36	300	82.76	AH4-3618-84	42	500	96.98
36" x 24"	A4-3624-84W	89	300	115.31	AH4-3624-84W	117	500	145.77	A4-3624-84	37	300	85.36	AH4-3624-84	45	500	103.82
48" x 12"	A4-4812-84W	75	225	108.97	AH4-4812-84W	95	375	135.53	A4-4812-84	39	225	89.00	AH4-4812-84	47	375	107.43
48" x 18"	A4-4818-84W	93	225	121.55	AH4-4818-84W	121	375	154.20	A4-4818-84	40	225	91.60	AH4-4818-84	49	375	112.26
48" x 24"	A4-4824-84W	112	225	134.12	AH4-4824-84W	147	375	172.41	A4-4824-84	42	225	94.19	AH4-4824-84	51	375	116.51
48" x 36"	A4-4836-84W	149	225	172.61	AH4-4836-84W	200	375	210.05	A4-4836-84	46	225	112.71	AH4-4836-84	56	375	126.20
60" x 12"	A4-6012-84W	94	150	142.66	AH4-6012-84W	109	250	157.59	A4-6012-84	54	150	117.70	AH4-6012-84	57	250	122.64
60" x 18"	A4-6018-84W	116	150	157.74	AH4-6018-84W	138	250	179.90	A4-6018-84	56	150	120.30	AH4-6018-84	59	250	127.49
60" x 24"	A4-6024-84W	173	150	172.82	AH4-6024-84W	166	250	201.62	A4-6024-84	57	150	122.89	AH4-6024-84	61	250	131.74
60" x 36"	A4-6036-84W	233	150	216.29	AH4-6036-84W	223	250	246.21	A4-6036-84	66	150	141.41	AH4-6036-84	66	250	141.41
5-SHELF UNITS																
36" x 12"	A5-3612-84W	71	300	105.18	AH5-3612-84W	92	500	134.53	A5-3612-84	41	300	86.46	AH5-3612-84	47	500	108.33
36" x 18"	A5-3618-84W	88	300	117.13	AH5-3618-84W	117	500	153.60	A5-3618-84	43	300	89.06	AH5-3618-84	48	500	111.70
36" x 24"	A5-3624-84W	104	300	129.08	AH5-3624-84W	142	500	171.76	A5-3624-84	44	300	91.65	AH5-3624-84	52	500	119.35
48" x 12"	A5-4812-84W	86	225	121.82	AH5-4812-84W	115	375	159.43	A5-4812-84	48	225	96.86	AH5-4812-84	55	375	124.49
48" x 18"	A5-4818-84W	108	225	136.90	AH5-4818-84W	147	375	182.87	A5-4818-84	49	225	99.47	AH5-4818-84	57	375	130.47
48" x 24"	A5-4824-84W	131	225	151.97	AH5-4824-84W	180	375	205.41	A5-4824-84	51	225	102.06	AH5-4824-84	60	375	135.53
48" x 36"	A5-4836-84W	176	225	201.75	AH5-4836-84W	245	375	251.91	A5-4836-84	54	225	126.87	AH5-4836-84	65	375	147.08
60" x 12"	A5-6012-84W	130	150	166.55	AH5-6012-84W	133	250	186.45	A5-6012-84	63	150	135.34	AH5-6012-84	66	250	142.77
60" x 18"	A5-6018-84W	158	150	184.75	AH5-6018-84W	170	250	214.25	A5-6018-84	64	150	137.96	AH5-6018-84	69	250	148.73
60" x 24"	A5-6024-84W	201	150	202.94	AH5-6024-84W	207	250	241.16	A5-6024-84	65	150	140.54	AH5-6024-84	71	250	153.80
60" x 36"	A5-6036-84W	271	150	258.95	AH5-6036-84W	279	250	296.39	A5-6036-84	77	150	165.36	AH5-6036-84	77	250	165.36
6-SHELF UNITS																
36" x 12"	A6-3612-84W	80	300	115.21	AH6-3612-84W	107	500	153.34	A6-3612-84	41	300	92.75	AH6-3612-84	53	500	121.91
36" x 18"	A6-3618-84W	100	300	129.04	AH6-3618-84W	137	500	176.15	A6-3618-84	43	300	95.35	AH6-3618-84	56	500	128.99
36" x 24"	A6-3624-84W	119	300	142.86	AH6-3624-84W	167	500	197.77	A6-3624-84	46	300	97.94	AH6-3624-84	59	500	134.88
48" x 12"	A6-4812-84W	97	225	134.67	AH6-4812-84W	134	375	183.49	A6-4812-84	41	225	104.72	AH6-4812-84	62	375	141.56
48" x 18"	A6-4818-84W	123	225	152.25	AH6-4818-84W	173	375	211.56	A6-4818-84	48	225	107.32	AH6-4818-84	65	375	148.66
48" x 24"	A6-4824-84W	151	225	169.82	AH6-4824-84W	212	375	238.41	A6-4824-84	51	225	109.92	AH6-4824-84	68	375	154.55
48" x 36"	A6-4836-84W	203	225	230.87	AH6-4836-84W	290	375	293.77	A6-4836-84	54	225	141.02	AH6-4836-84	74	375	167.97
60" x 12"	A6-6012-84W	125	150	190.44	AH6-6012-84W	156	250	215.29	A6-6012-84	71	150	153.00	AH6-6012-84	76	250	162.89
60" x 18"	A6-6018-84W	152	150	211.75	AH6-6018-84W	200	250	248.58	A6-6018-84	72	150	155.60	AH6-6018-84	78	250	169.97
60" x 24"	A6-6024-84W	206	150	233.06	AH6-6024-84W	244	250	280.68	A6-6024-84	74	150	158.19	AH6-6024-84	82	250	175.85
60" x 36"	A6-6036-84W	250	150	301.60	AH6-6036-84W	331	250	346.53	A6-6036-84	88	150	189.29	AH6-6036-84	88	250	189.29

Extra Shelves with Decking

Extra Shelves w/o Decking

W X D	MODEL #	WT.	CAP.	PRICE	MODEL #	WT.	CAP.	PRICE	MODEL #	WT.	CAP.	PRICE	MODEL #	WT.	CAP.	PRICE
REGULAR DUTY				HEAVY DUTY				REGULAR DUTY				HEAVY DUTY				
36" x 12"	AX1-3612-W	10	300	10.03	AXH1-3612-W	16	500	18.82	AX1-3612	3	300	6.29	AXH1-3612	7	500	13.58
36" x 18"	AX1-3618-W	13	300	11.91	AXH1-3618-W	21	500	22.57	AX1-3618	3	300	6.29	AXH1-3618	7	500	14.69
36" x 24"	AX1-3624-W	16	300	13.77	AXH1-3624-W	25	500	26.01	AX1-3624	3	300	6.29	AXH1-3624	7	500	15.53
48" x 12"	AX1-4812-W	13	225	12.85	AXH1-4812-W	20	375	24.06	AX1-4812	4	225	7.86	AXH1-4812	8	375	17.08
48" x 18"	AX1-4818-W	17	225	15.34	AXH1-4818-W	27	375	28.68	AX1-4818	4	225	7.86	AXH1-4818	8	375	18.19
48" x 24"	AX1-4824-W	21	225	17.85	AXH1-4824-W	33	375	33.00	AX1-4824	4	225	7.86	AXH1-4824	8	375	19.02
48" x 36"	AX1-4836-W	28	225	29.13	AXH1-4836-W	46	375	41.86	AX1-4836	4	225	7.86	AXH1-4836	8	375	20.89
60" x 12"	AX1-6012-W	20	150	23.88	AXH1-6012-W	25	250	28.86	AX1-6012	9	150	17.64	AXH1-6012	10	250	20.12
60" x 18"	AX1-6018-W	25	150	27.00	AXH1-6018-W	33	250	34.35	AX1-6018	9	150	17.64	AXH1-6018	10	250	21.24
60" x 24"	AX1-6024-W	29	150	30.12	AXH1-6024-W	41	250	39.54	AX1-6024	9	150	17.64	AXH1-6024	10	250	22.06
60" x 36"	AX1-6036-W	39	150	36.37	AXH1-6036-W	56	250	50.14	AX1-6036	11	150	23.94	AXH1-6036	11	250	23.94

WIRE SHELVING COMPONENTS

Wire Shelving components can be purchased separately to meet your specific requirements. Shelves can be adjusted in 1" increments and we offer a variety of post sizes. Stationary posts include an adjustable leveling bolt to compensate for uneven surfaces. Components are available in Chrome Plated, and Black Powder Coat. Chrome and Black Wire Shelving are NSF certified by the National Sanitation Foundation.

WIRE SHELVING POSTS

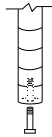

Stationary Posts

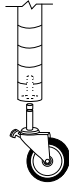

Mobile Posts

HEIGHT	MODEL NUMBER	WEIGHT	PRICE	MODEL NUMBER	WEIGHT	PRICE
CHROME POSTS						
36" Stationary	N/A	N/A	N/A	205-BP36	1.5	\$5.92
63" Stationary	205-CP63	3.7	\$12.94	205-BP63	5.2	10.35
74" Stationary	205-CP74	4.0	14.87	205-BP74	3.5	10.94
86" Stationary	205-CP86	5.1	17.38	205-BP86	3.6	12.90
BLACK POSTS						
30" Mobile	N/A	N/A	N/A	205-BP30M	1.3	\$4.92
63" Mobile	205-CP63M	3.5	\$12.63	205-BP63M	2.5	10.03
74" Mobile	205-CP74M	4.0	14.55	205-BP74M	3.5	10.61

WIRE SHELVES

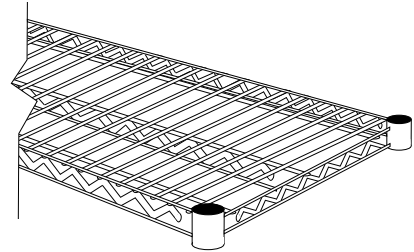

WIRE SHELVING ACCESSORIES

SIZE	MODEL #	WT.	PRICE
(A) CHROME BASKET SHELVES			
18"D x 36"W	205-CSB1836	9.9	\$72.81
(B) CHROME SHELF DIVIDERS			
18"D	205-CSD18	2.5	\$11.65
24"D	205-CSD24	2.6	15.54
(C) CHROME CANTILEVER SHELVES			
12"D x 36"W	205-CSC1236	7.1	\$19.25
12"D x 48"W	205-CSC1248	7.6	24.97
12"D x 60"W	205-CSC1260	8.1	28.90
(D) CHROME LEDGES			
18"D	205-CL18	0.7	\$3.96
24"D	205-CL24	1.0	4.98
36"D	205-CL36	1.7	7.14
48"D	205-CL48	2.4	8.63
60"D	205-CL60	2.5	
(E) CHROME SAFETY HANDLES			
18"D	205-CSF18	0.9	\$12.63
24"D	205-CSF24	1.2	14.56
36"D	205-CSF36	1.8	17.23
(F) CHROME UTILITY HANDLES			
18"D	205-CH18	3.7	\$20.14
24"D	205-CH24	3.9	22.53
(G) CHROME DOCUMENT HOLDER			
N/A	205-CDH	1.3	\$17.97

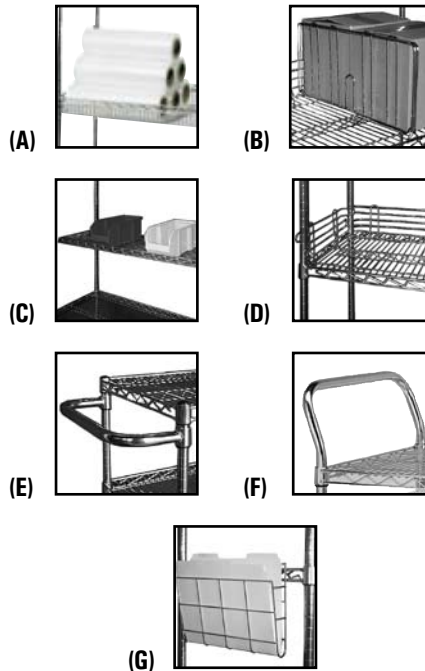

MODEL #	SIZE	WT.	PRICE
CHROME			
205-CS1836	18" x 36"	9.5	31.44
205-CS1842	18" x 42"	10.4	37.85
205-CS1848	18" x 48"	12.0	40.66
205-CS1854	18" x 54"	13.8	46.31
205-CS1860	18" x 60"	17.0	47.55
205-CS1872	18" x 72"	20.0	55.23
205-CS2136	21" x 36"	9.8	37.45
205-CS2142	21" x 42"	11.8	44.19
205-CS2148	21" x 48"	13.0	46.71
205-CS2154	21" x 54"	14.2	54.12
205-CS2160	21" x 60"	16.0	56.37
205-CS2172	21" x 72"	19.0	66.04
205-CS2436	24" x 36"	12.3	39.89
205-CS2442	24" x 42"	13.4	46.31
205-CS2448	24" x 48"	16.0	48.33
205-CS2454	24" x 54"	18.0	56.78
205-CS2460	24" x 60"	21.0	59.83
205-CS2472	24" x 72"	26.0	70.57
205-CS3648	36" x 48"	26.7	87.83
205-CS3660	36" x 60"	31.7	109.23
205-CS3672	36" x 72"	38.3	122.33
BLACK			
205-BS1836	18" x 36"	8.5	26.42
205-BS1848	18" x 48"	11.5	31.89
205-BS1860	18" x 60"	13.0	43.69
205-BS1872	18" x 72"	15.4	50.87
205-BS2436	24" x 36"	12.0	33.26
205-BS2448	24" x 48"	15.0	40.99
205-BS2460	24" x 60"	18.2	54.38
205-BS2472	24" x 72"	22.0	65.05

MISCELLANEOUS PARTS

MODEL #	DESCRIPTION	WT.	PRICE
205-CSHOOK1	"S" Style Hook for Chrome	0.8	\$1.51
205-BSHOOK1	"S" Style Hook for Black	0.8	1.26
205-AC5L	5" Locking Caster Wheel	2.4	\$14.56
205-CPA	Stationary Post Anchor	0.1	\$4.49
205-CSCLIP1	Chrome/Black Shelf Clip	0.2	\$0.36
205-CPMB	Wall Mount Bracket	0.4	\$7.49
205-CPC	Chrome Shelving Post Clamps	0.4	\$5.69
205-BPC	Black Shelving Post Clamps	0.4	5.09

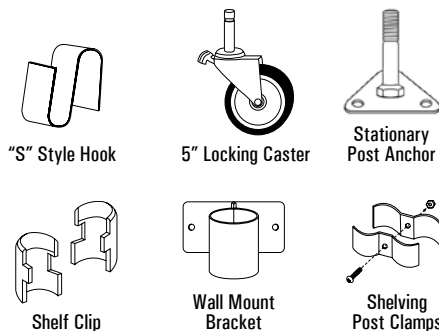

LABEL HOLDERS

- Snap-On label holders.
- Flexible holders fit 1 1/4" wire shelving faces.
- Includes laser / inkjet white inserts.

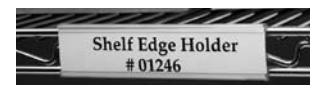

MODEL #	DESCRIPTION	WT.	PRICE
205-CL1253	3" Long / 25 per pack	2.0	\$40.00
205-CL1256	6" Long / 25 per pack	2.0	69.12

CHROME STATIONARY WIRE SHELVING

- Open wire construction reduces dust built-up, allows free light and air circulation, increases sprinkler effectiveness and improves visibility.
- Fast and easy assembly, no tools are required.
- Each shelf is adjustable in 1" increments.
- Starter Unit consists of 4 posts, 4 shelves, 4 adjustable feet and 16 shelf clips.
- Add-On unit consists of 2 posts, 4 shelves, 4 adjustable feet, 8 add-on hooks and 8 shelf clips.
- Add additional shelves to meet your specific needs.

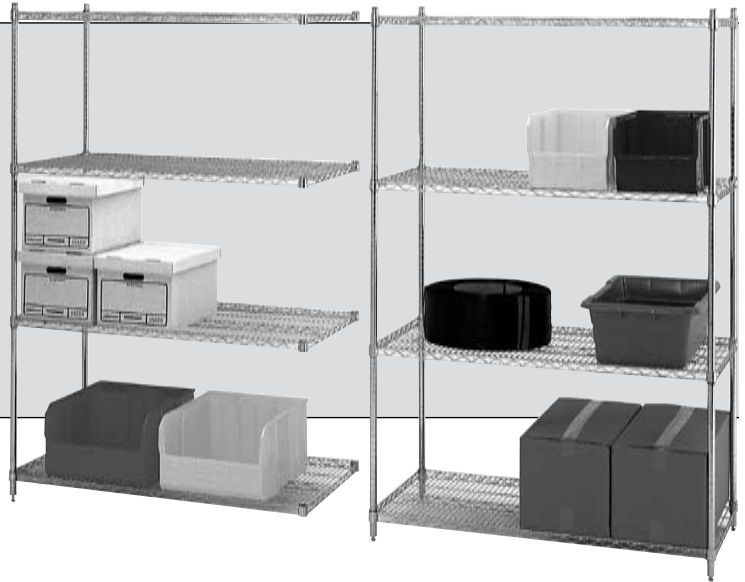

63" High Units				74" High Units				86" High Units				Extra Shelf			
SIZE	MODEL NUMBER	WT.	PRICE	MODEL NUMBER	WT.	PRICE	MODEL NUMBER	WT.	PRICE	MODEL NUMBER	WT.	PRICE	MODEL NUMBER	WT.	PRICE
4 SHELF - STARTER UNIT															
18" x 36"	WCS4-1836-63	56	177.52	WCS4-1836-74	57	185.24	WCS4-1836-86	59.8	195.25	205-CS1836	9.5	31.44			
18" x 42"	WCS4-1842-63	60	203.16	WCS4-1842-74	61	210.88	WCS4-1842-86	63.8	220.89	205-CS1842	10.4	37.85			
18" x 48"	WCS4-1848-63	66	214.00	WCS4-1848-74	67	222.09	WCS4-1848-86	69.8	232.10	205-CS1848	12.0	40.66			
18" x 54"	WCS4-1854-63	74	236.99	WCS4-1854-74	75	244.71	WCS4-1854-86	77.8	254.72	205-CS1854	13.8	46.31			
18" x 60"	WCS4-1860-63	86	241.95	WCS4-1860-74	87	249.66	WCS4-1860-86	89.8	259.68	205-CS1860	17.0	47.55			
18" x 72"	WCS4-1872-63	98	272.67	WCS4-1872-74	99	280.38	WCS4-1872-86	101.8	290.40	205-CS1872	20.0	55.23			
21" x 36"	WCS4-2136-63	58	201.56	WCS4-2136-74	59	209.27	WCS4-2136-86	61.8	219.29	205-CS2136	9.8	37.45			
21" x 42"	WCS4-2142-63	66	228.50	WCS4-2142-74	67	236.21	WCS4-2142-86	69.8	246.23	205-CS2142	11.8	44.19			
21" x 48"	WCS4-2148-63	70	238.59	WCS4-2148-74	71	246.31	WCS4-2148-86	73.8	256.33	205-CS2148	13.0	46.71			
21" x 54"	WCS4-2154-63	75	268.25	WCS4-2154-74	76	275.97	WCS4-2154-86	78.8	285.99	205-CS2154	14.2	54.12			
21" x 60"	WCS4-2160-63	82	277.24	WCS4-2160-74	83	284.95	WCS4-2160-86	85.8	294.97	205-CS2160	16.0	56.37			
21" x 72"	WCS4-2172-63	94	315.92	WCS4-2172-74	95	323.64	WCS4-2172-86	97.8	333.66	205-CS2172	19.0	66.04			
24" x 36"	WCS4-2436-63	68	211.31	WCS4-2436-74	69	219.03	WCS4-2436-86	71.8	229.04	205-CS2436	12.3	39.89			
24" x 42"	WCS4-2442-63	72	236.99	WCS4-2442-74	73	244.71	WCS4-2442-86	75.8	254.72	205-CS2442	13.4	46.31			
24" x 48"	WCS4-2448-63	82	245.04	WCS4-2448-74	83	252.77	WCS4-2448-86	85.8	262.78	205-CS2448	16.0	48.33			
24" x 54"	WCS4-2454-63	90	278.88	WCS4-2454-74	91	286.60	WCS4-2454-86	93.8	296.61	205-CS2454	18.0	56.78			
24" x 60"	WCS4-2460-63	102	291.07	WCS4-2460-74	103	298.79	WCS4-2460-86	105.8	308.80	205-CS2460	21.0	59.83			
24" x 72"	WCS4-2472-63	122	334.03	WCS4-2472-74	123	341.75	WCS4-2472-86	125.8	351.76	205-CS2472	26.0	70.57			
36" x 48"	WCS4-3648-63	125	403.02	WCS4-3648-74	126	410.73	WCS4-3648-86	128.8	420.75	205-CS3648	26.7	87.83			
36" x 60"	WCS4-3660-63	145	488.64	WCS4-3660-74	146	496.36	WCS4-3660-86	148.8	506.38	205-CS3660	31.7	109.23			
36" x 72"	WCS4-3672-63	172	541.07	WCS4-3672-74	173	548.78	WCS4-3672-86	175.8	558.80	205-CS3672	38.3	122.33			
4 SHELF - ADD-ON UNIT															
18" x 36"	WCT4-1836-63	55	151.65	WCT4-1836-74	56	155.51	WCT4-1836-86	57.4	160.71	205-CS1836	9.5	31.44			
18" x 42"	WCT4-1842-63	59	177.29	WCT4-1842-74	60	181.14	WCT4-1842-86	61.4	186.15	205-CS1842	10.4	37.85			
18" x 48"	WCT4-1848-63	65	188.49	WCT4-1848-74	66	192.36	WCT4-1848-86	67.4	197.37	205-CS1848	12.0	40.66			
18" x 54"	WCT4-1854-63	73	210.88	WCT4-1854-74	74	214.97	WCT4-1854-86	75.4	219.98	205-CS1854	13.8	46.31			
18" x 60"	WCT4-1860-63	85	216.07	WCT4-1860-74	86	219.93	WCT4-1860-86	87.4	224.94	205-CS1860	17.0	47.55			
18" x 72"	WCT4-1872-63	97	246.81	WCT4-1872-74	98	250.66	WCT4-1872-86	99.4	255.67	205-CS1872	20.0	55.23			
21" x 36"	WCT4-2136-63	57	175.67	WCT4-2136-74	58	179.55	WCT4-2136-86	59.4	184.55	205-CS2136	9.8	37.45			
21" x 42"	WCT4-2142-63	65	202.63	WCT4-2142-74	66	206.48	WCT4-2142-86	66.4	211.49	205-CS2142	11.8	44.19			
21" x 48"	WCT4-2148-63	69	212.72	WCT4-2148-74	70	216.58	WCT4-2148-86	71.4	221.59	205-CS2148	13.0	46.71			
21" x 54"	WCT4-2154-63	74	242.38	WCT4-2154-74	75	246.24	WCT4-2154-86	76.4	251.25	205-CS2154	14.2	54.12			
21" x 60"	WCT4-2160-63	81	251.36	WCT4-2160-74	82	255.22	WCT4-2160-86	83.4	260.22	205-CS2160	16.0	56.37			
21" x 72"	WCT4-2172-63	93	290.04	WCT4-2172-74	94	293.91	WCT4-2172-86	95.4	298.92	205-CS2172	19.0	66.04			
24" x 36"	WCT4-2436-63	67	185.44	WCT4-2436-74	68	189.29	WCT4-2436-86	69.4	194.30	205-CS2436	12.3	39.89			
24" x 42"	WCT4-2442-63	71	211.12	WCT4-2442-74	72	214.97	WCT4-2442-86	73.4	219.98	205-CS2442	13.4	46.31			
24" x 48"	WCT4-2448-63	81	219.17	WCT4-2448-74	82	223.03	WCT4-2448-86	83.4	228.04	205-CS2448	16.0	48.33			
24" x 54"	WCT4-2454-63	89	253.00	WCT4-2454-74	90	256.87	WCT4-2454-86	91.4	261.88	205-CS2454	18.0	56.78			
24" x 60"	WCT4-2460-63	101	265.20	WCT4-2460-74	102	269.05	WCT4-2460-86	103.4	274.06	205-CS2460	21.0	59.83			
24" x 72"	WCT4-2472-63	121	308.15	WCT4-2472-74	122	312.02	WCT4-2472-86	123.4	317.03	205-CS2472	26.0	70.57			
36" x 48"	WCT4-3648-63	124	377.13	WCT4-3648-74	125	381.01	WCT4-3648-86	126.4	386.01	205-CS3648	26.7	87.83			
36" x 60"	WCT4-3660-63	144	462.76	WCT4-3660-74	145	466.64	WCT4-3660-86	146.4	471.65	205-CS3660	31.7	109.23			
36" x 72"	WCT4-3672-63	171	515.19	WCT4-3672-74	172	519.06	WCT4-3672-86	173.4	524.06	205-CS3672	38.3	122.33			

CHROME MOBILE WIRE UTILITY CARTS

- Mobile carts are finished with durable chrome plating.
- Open wire design reduces dust build-up, improves lighting and air circulation.
- Carts are highly maneuverable and include four locking 5" swivel caster wheels.
- Easy to assemble and no special tools required.
- Shelves are fully adjustable in 1" increments.
- Units are 39" high and available with 2 or 3 shelves.



2 Shelf Cart				3 Shelf Cart		
SHELF SIZE	MODEL NUMBER	WEIGHT	PRICE	MODEL NUMBER	WEIGHT	PRICE
18" x 36"	WCD2-1836	38	161.41	WCD3-1836	48	192.85
18" x 42"	WCD2-1842	40	174.23	WCD3-1842	51	212.07
18" x 48"	WCD2-1848	43	179.82	WCD3-1848	55	220.48
18" x 54"	WCD2-1854	47	191.14	WCD3-1854	61	237.45
18" x 60"	WCD2-1860	53	193.62	WCD3-1860	70	241.17
18" x 72"	WCD2-1872	59	208.98	WCD3-1872	79	264.22
24" x 36"	WCD2-2436	44	183.11	WCD3-2436	68	223.00
24" x 42"	WCD2-2442	46	191.14	WCD3-2442	60	237.45
24" x 48"	WCD2-2448	52	199.97	WCD3-2448	68	248.30
24" x 54"	WCD2-2454	55	212.08	WCD3-2454	74	268.87
24" x 60"	WCD2-2460	62	222.99	WCD3-2460	83	282.81
24" x 72"	WCD2-2472	72	244.46	WCD3-2472	98	315.04

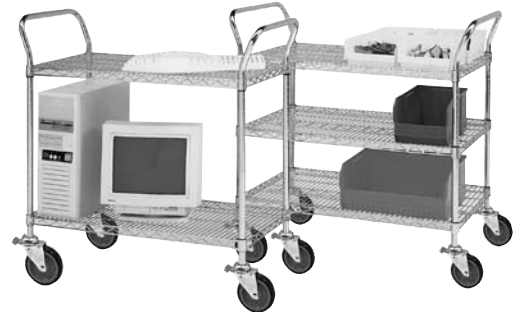

CHROME MOBILE WIRE SHELVING

- Constructed to the highest quality standards and feature rust resistant chrome plating.
- Attractive open wire design reduces dust build-up, improves lighting and air circulation.
- Units are highly maneuverable and come standard with locking 5" diameter swivel caster wheels.
- Easy to assemble and no special tools required.
- Units come standard with 4 shelves.



69" High Units				80" High Units			Extra Shelf			
SHELF SIZE	SHELF CAP.	MODEL NUMBER	WEIGHT	PRICE	MODEL NUMBER	WEIGHT	PRICE	MODEL NUMBER	WEIGHT	PRICE
18" x 36"	500	WCC4-1836-63	65	234.52	WCC4-1836-74	66.2	242.23	205-CS1836	9.5	31.44
18" x 42"	500	WCC4-1842-63	69	260.15	WCC4-1842-74	70.2	267.85	205-CS1842	10.4	37.85
18" x 48"	500	WCC4-1848-63	75	271.36	WCC4-1848-74	76.2	279.07	205-CS1848	12.0	40.66
18" x 54"	400	WCC4-1854-63	82	293.98	WCC4-1854-74	83.2	301.69	205-CS1854	13.8	46.31
18" x 60"	400	WCC4-1860-63	95	298.93	WCC4-1860-74	96.2	306.63	205-CS1860	17.0	47.55
18" x 72"	400	WCC4-1872-63	107	329.66	WCC4-1872-74	108.2	337.36	205-CS1872	20.0	55.23
21" x 36"	500	WCC4-2136-63	66	258.54	WCC4-2136-74	67.2	266.25	205-CS2136	9.8	37.45
21" x 42"	500	WCC4-2142-63	74	285.49	WCC4-2142-74	75.2	293.19	205-CS2142	11.8	44.19
21" x 48"	500	WCC4-2148-63	79	295.59	WCC4-2148-74	80.2	303.29	205-CS2148	13.0	46.71
21" x 54"	400	WCC4-2154-63	84	325.25	WCC4-2154-74	85.2	332.95	205-CS2154	14.2	54.12
21" x 60"	400	WCC4-2160-63	91	334.23	WCC4-2160-74	92.2	341.93	205-CS2160	16.0	56.37
21" x 72"	400	WCC4-2172-63	103	372.92	WCC4-2172-74	104.2	380.62	205-CS2172	19.0	66.04
24" x 36"	500	WCC4-2436-63	76	268.30	WCC4-2436-74	77.2	276.01	205-CS2436	12.3	39.89
24" x 42"	500	WCC4-2442-63	81	293.98	WCC4-2442-74	82.2	301.69	205-CS2442	13.4	46.31
24" x 48"	500	WCC4-2448-63	91	301.55	WCC4-2448-74	92.2	309.25	205-CS2448	16.0	48.33
24" x 54"	400	WCC4-2454-63	99	335.87	WCC4-2454-74	100.2	343.58	205-CS2454	18.0	56.78
24" x 60"	400	WCC4-2460-63	111	348.06	WCC4-2460-74	112.2	355.76	205-CS2460	21.0	59.83
24" x 72"	400	WCC4-2472-63	131	391.02	WCC4-2472-74	132.2	398.72	205-CS2472	26.0	70.57
36" x 48"	500	WCC4-3648-63	134	459.99	WCC4-3648-74	135.2	467.70	205-CS3648	26.7	87.83
36" x 60"	400	WCC4-3660-63	154	545.63	WCC4-3660-74	155.2	553.33	205-CS3660	31.7	109.23
36" x 72"	300	WCC4-3672-63	180	598.07	WCC4-3672-74	181.2	605.77	205-CS3672	38.3	122.33

BLACK POWDER COATED STATIONARY WIRE SHELVING

- Open wire construction reduces dust build-up, allows free light and air circulation, increases sprinkler effectiveness and improves visibility.
- Finished in a durable black powder coated paint.
- Easy to assemble and no tools required.
- Shelves are adjustable in 1" increments.
- Units come standard with 4 shelves, order additional shelves to meet your specific needs.



63" High				74" High				86" High				Extra Shelf			
SHELF SIZE	MODEL NUMBER	WT.	PRICE	MODEL NUMBER	WT.	PRICE	MODEL NUMBER	WT.	PRICE	MODEL NUMBER	WT.	PRICE	MODEL NUMBER	WT.	PRICE
4 SHELF STARTER UNITS															
18" x 36"	WBS4-1836-63	61		WBS4-1836-74	49		WBS4-1836-86	62		205-BS1836	9				
18" x 48"	WBS4-1848-63	67		WBS4-1848-74	61		WBS4-1848-86	68		205-BS1848	12				
18" x 60"	WBS4-1860-63	69		WBS4-1860-74	67		WBS4-1860-86	70		205-BS1860	13				
18" x 72"	WBS4-1872-63	73		WBS4-1872-74	76		WBS4-1872-86	74		205-BS1872	16				
24" x 36"	WBS4-2436-63	75		WBS4-2436-74	63		WBS4-2436-86	76		205-BS2436	12				
24" x 48"	WBS4-2448-63	88		WBS4-2448-74	75		WBS4-2448-86	89		205-BS2448	15				
24" x 60"	WBS4-2460-63	103		WBS4-2460-74	88		WBS4-2460-86	104		205-BS2460	19				
24" x 72"	WBS4-2472-63	119		WBS4-2472-74	103		WBS4-2472-86	120		205-BS2472	22				
4 SHELF ADD-ON UNITS															
18" x 36"	WBT4-1836-63	55		WBT4-1836-74	42		WBT4-1836-86	55		205-BS1836	9				
18" x 48"	WBT4-1848-63	61		WBT4-1848-74	54		WBT4-1848-86	61		205-BS1848	12				
18" x 60"	WBT4-1860-63	63		WBT4-1860-74	60		WBT4-1860-86	63		205-BS1860	13				
18" x 72"	WBT4-1872-63	67		WBT4-1872-74	69		WBT4-1872-86	67		205-BS1872	16				
24" x 36"	WBT4-2436-63	69		WBT4-2436-74	56		WBT4-2436-86	69		205-BS2436	12				
24" x 48"	WBT4-2448-63	82		WBT4-2448-74	65		WBT4-2448-86	82		205-BS2448	15				
24" x 60"	WBT4-2460-63	97		WBT4-2460-74	81		WBT4-2460-86	97		205-BS2460	19				
24" x 72"	WBT4-2472-63	113		WBT4-2472-74	96		WBT4-2472-86	113		205-BS2472	22				

BLACK POWDER COATED MOBILE WIRE SHELVING

- These mobile wire shelving units are attractive and highly functional.
- Open wire design reduces dust built up and improves air circulation.
- Units include four 5" locking swivel casters.
- Powder coated black finish is chip and scratch resistant.
- Shelves are adjustable in 1" increments.
- Easy to assemble and no special tools required.
- Maximum unit capacity: 700 lbs.



36" High				69" High				80" High				Extra Shelf			
SHELF SIZE	MODEL NUMBER	WT.	PRICE	MODEL NUMBER	WT.	PRICE	MODEL NUMBER	WT.	PRICE	MODEL NUMBER	WT.	PRICE	MODEL NUMBER	WT.	PRICE
2 SHELF UNIT															
18" x 36"	WBC2-1836-30	39		WBC4-1836-63	54		WBC4-1836-74	71		205-BS1836	9				
18" x 48"	WBC2-1848-30	42		WBC4-1848-63	66		WBC4-1848-74	77		205-BS1848	12				
18" x 60"	WBC2-1860-30	43		WBC4-1860-63	72		WBC4-1860-74	79		205-BS1860	14				
18" x 72"	WBC2-1872-30	45		WBC4-1872-63	81		WBC4-1872-74	83		205-BS1872	16				
4 SHELF UNIT															
24" x 36"	WBC2-2436-30	46		WBC4-2436-63	68		WBC4-2436-74	85		205-BS2436	12				
24" x 48"	WBC2-2448-30	53		WBC4-2448-63	80		WBC4-2448-74	98		205-BS2448	15				
24" x 60"	WBC2-2460-30	60		WBC4-2460-63	92		WBC4-2460-74	113		205-BS2460	19				
24" x 72"	WBC2-2472-30	68		WBC4-2472-63	108		WBC4-2472-74	129		205-BS2472	22				
1 SHELF															

HEIGHT ADJUSTABLE WORKBENCHES

- Worksurface height from the floor can be adjusted from 29^{1/4"} - 25^{1/4"}.
- Available in a variety of configurations to fit your specific needs and budget.
- Unit comes with durable steel (S) or shop top (T) worksurface.
- All welded steel legs are designed to support the most demanding applications.
- Elevated shelves are 12" above worksurface and are 10" deep.



Worksurface Only

W X D	MODEL #	WT.	PRICE	MODEL #	WT.	PRICE
	(T) SHOP TOP			(S) STEEL TOP		
60" x 30"	G55T-6030	101		G55S-6030	100	
60" x 36"	G55T-6036	106		G55S-6036	102	
72" x 30"	G55T-7230	116		G55S-7230	112	
72" x 36"	G55T-7236	117		G55S-7236	114	



Worksurface with Bottom Shelf

W X D	MODEL #	WT.	PRICE	MODEL #	WT.	PRICE
	(T) SHOP TOP			(S) STEEL TOP		
60" x 30"	G56T-6030	120		G56S-6030	119	
60" x 36"	G56T-6036	125		G56S-6036	121	
72" x 30"	G56T-7230	140		G56S-7230	136	
72" x 36"	G56T-7236	141		G56S-7236	138	



Worksurface with Bottom Shelf & Riser

W X D	MODEL #	WT.	PRICE	MODEL #	WT.	PRICE
	(T) SHOP TOP			(S) STEEL TOP		
60" x 30"	G58T-6030	144		G58S-6030	143	
60" x 36"	G58T-6036	149		G58S-6036	145	
72" x 30"	G58T-7230	167		G58S-7230	163	
72" x 36"	G58T-7236	168		G58S-7236	165	



Worksurface with Bottom Shelf & Riser

W X D	MODEL #	WT.	PRICE	MODEL #	WT.	PRICE
	(T) SHOP TOP			(S) STEEL TOP		
60" x 30"	G59T-6030	163		G59S-6030	162	
60" x 36"	G59T-6036	168		G59S-6036	164	
72" x 30"	G59T-7230	186		G59S-7230	182	
72" x 36"	G59T-7236	187		G59S-7236	184	

FASTRAK WORKBENCH

- Utilizes the same heavy-duty components as our popular FastRak bulk shelving.
- Worksurface is approximately 36" high.
- Thick 3/4" particle board fits inside step beams and is supported by steel supports to provide an exceptionally strong worksurface.
- FastRak Workbenches feature a newly designed heavier duty upright that can be "knocked down" for easier shipment.



Single Shelf

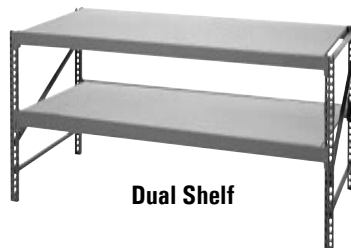

Dual Shelf

For additional safety, optional deluxe foot plates and concrete wedge anchors are available.



MODEL #	PRICE
DELUXE FOOT PLATES	
CUCF01	\$
CONCRETE WEDGE ANCHOR	
235-FA01	\$

Single Shelf Workbench

SHELF SIZE	MODEL NUMBER	SHELF CAP.	WEIGHT	*PRICE
48"W x 36"D	KB1-4836-W	2,000	106	
48"W x 48"D	KB1-4848-W	2,000	122	
72"W x 36"D	KB1-7236-W	1,800	136	
72"W x 48"D	KB1-7248-W	1,800	158	
96"W x 36"D	KB1-9636-W	1,600	159	
96"W x 48"D	KB1-9648-W	1,600	187	

Dual Shelf Workbench

SHELF SIZE	MODEL NUMBER	SHELF CAP.	WEIGHT	*PRICE
48"W x 36"D	KB2-4836-W	2,000	156	
48"W x 48"D	KB2-4848-W	2,000	185	
72"W x 36"D	KB2-7236-W	1,800	209	
72"W x 48"D	KB2-7248-W	1,800	249	
96"W x 36"D	KB2-9636-W	1,600	253	
96"W x 48"D	KB2-9648-W	1,600	305	

**Units priced with unassembled uprights, please contact us for assembled upright pricing.*

SERIES 200B WORKBENCH / PACKING TABLES

- Available in a variety of sizes and configurations to fit your specific needs.
- These units utilize the Series 200B design which allows for quick and easy assembly.
- All worksurfaces are 36" high from floor.
- Elevated shelves are 24" above worksurface and 12" deep.
- These units are available with or without 1/2" particle board decking.



W X D	With Decking			Without Decking			With Decking			Without Decking		
	MODEL NUMBER	WT.	PRICE	MODEL NUMBER	WT.	PRICE	MODEL NUMBER	WT.	PRICE	MODEL NUMBER	WT.	PRICE
(A) WORKSURFACE ONLY						(B) WORKSURFACE PLUS BOTTOM SHELF						
48" x 24"	BW1-4824-W	38		BW1-4824	21		BW2-4824-W	59		BW2-4824	23	
48" x 30"	BW1-4830-W	44		BW1-4830	22		BW2-4830-W	69		BW2-4830	25	
48" x 36"	BW1-4836-W	50		BW1-4836	23		BW2-4836-W	79		BW2-4836	26	
48" x 48"	BW1-4848-W	61		BW1-4848	26		BW2-4848-W	99		BW2-4848	28	
60" x 24"	BW1-6024-W	47		BW1-6024	25		BW2-6024-W	73		BW2-6024	29	
60" x 30"	BW1-6030-W	54		BW1-6030	27		BW2-6030-W	86		BW2-6030	31	
60" x 36"	BW1-6036-W	61		BW1-6036	28		BW2-6036-W	98		BW2-6036	32	
60" x 48"	BW1-6048-W	74		BW1-6048	30		BW2-6048-W	123		BW2-6048	35	
72" x 24"	BW1-7224-W	56		BW1-7224	29		BW2-7224-W	88		BW2-7224	35	
72" x 30"	BW1-7230-W	64		BW1-7230	31		BW2-7230-W	103		BW2-7230	37	
72" x 36"	BW1-7236-W	72		BW1-7236	32		BW2-7236-W	118		BW2-7236	39	
72" x 48"	BW1-7248-W	88		BW1-7248	35		BW2-7248-W	149		BW2-7248	43	
96" x 24"	BW1-9624-W	69		BW1-9624	34		BW2-9624-W	112		BW2-9624	42	
96" x 30"	BW1-9630-W	80		BW1-9630	36		BW2-9630-W	132		BW2-9630	44	
96" x 36"	BW1-9636-W	90		BW1-9636	37		BW2-9636-W	151		BW2-9636	46	
96" x 48"	BW1-9648-W	111		BW1-9648	40		BW2-9648-W	190		BW2-9648	49	

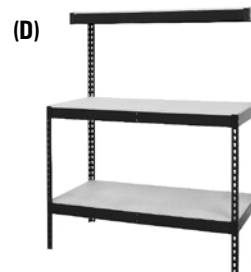
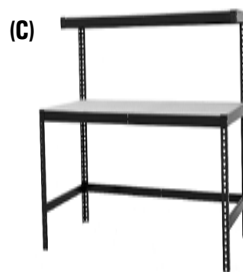

W X D	With Decking			Without Decking			With Decking			Without Decking		
	MODEL NUMBER	WT.	PRICE	MODEL NUMBER	WT.	PRICE	MODEL NUMBER	WT.	PRICE	MODEL NUMBER	WT.	PRICE
(C) WORKSURFACE WITH TOP SHELF						(D) WORKSURFACE PLUS TOP & BOTTOM SHELF						
48" x 24"	BW3-4824-W	55		BW3-4824	28		BW4-4824-W	75		BW4-4824	31	
48" x 30"	BW3-4830-W	60		BW3-4830	29		BW4-4830-W	85		BW4-4830	32	
48" x 36"	BW3-4836-W	66		BW3-4836	31		BW4-4836-W	95		BW4-4836	33	
48" x 48"	BW3-4848-W	77		BW3-4848	33		BW4-4848-W	115		BW4-4848	36	
60" x 24"	BW3-6024-W	67		BW3-6024	34		BW4-6024-W	93		BW4-6024	38	
60" x 30"	BW3-6030-W	74		BW3-6030	35		BW4-6030-W	106		BW4-6030	40	
60" x 36"	BW3-6036-W	81		BW3-6036	37		BW4-6036-W	118		BW4-6036	41	
60" x 48"	BW3-6048-W	94		BW3-6048	39		BW4-6048-W	142		BW4-6048	43	
72" x 24"	BW3-7224-W	79		BW3-7224	39		BW4-7224-W	111		BW4-7224	45	
72" x 30"	BW3-7230-W	87		BW3-7230	40		BW4-7230-W	126		BW4-7230	47	
72" x 36"	BW3-7236-W	95		BW3-7236	42		BW4-7236-W	141		BW4-7236	49	
72" x 48"	BW3-7248-W	111		BW3-7248	45		BW4-7248-W	172		BW4-7248	53	
96" x 24"	BW3-9624-W	98		BW3-9624	45		BW4-9624-W	141		BW4-9624	53	
96" x 30"	BW3-9630-W	109		BW3-9630	47		BW4-9630-W	161		BW4-9630	55	
96" x 36"	BW3-9636-W	119		BW3-9636	49		BW4-9636-W	180		BW4-9636	57	
96" x 48"	BW3-9648-W	140		BW3-9648	52		BW4-9648-W	219		BW4-9648	61	

MOBILE WORKBENCHES

- Save time and money with these handy mobile workbenches.
- Bench easily rolls on two 5" swivel and two 5" rigid casters.
- All benches are 36" overall height with a 700 lb. capacity.
- Available in 2 or 3 shelf configurations.



2 Shelf Workbench				3 Shelf Workbench			Extra Shelf		
SIZE	MODEL #	WT.	PRICE	MODEL #	WT.	PRICE	MODEL #	WT.	PRICE
36" x 24"	BC2-3624-30W	52		BC3-3624-30W	72		BX1-3624-W	20	
48" x 12"	BC2-4812-30W	41		BC3-4812-30W	56		BX1-4812-W	16	
48" x 18"	BC2-4818-30W	52		BC3-4818-30W	72		BX1-4818-W	21	
48" x 24"	BC2-4824-30W	63		BC3-4824-30W	89		BX1-4824-W	26	
48" x 36"	BC2-4836-30W	86		BC3-4836-30W	122		BX1-4836-W	36	
60" x 24"	BC2-6024-30W	77		BC3-6024-30W	110		BX1-6024-W	33	
60" x 30"	BC2-6030-30W	90		BC3-6030-30W	129		BX1-6030-W	39	
60" x 36"	BC2-6036-30W	104		BC3-6036-30W	149		BX1-6036-W	46	

FASTRAK REEL RACKS

- Based on FastRak Bulk shelving, units are super strong and highly versatile.
- Beams attach quickly to uprights using popular "tear drop" design and feature a built-in locking clip for safety.
- Units include rod and rod brackets.
- Accommodates up to 48" rods.
- Each level can hold up to 350 lbs.
- Unit capacity is 6,000 lbs.

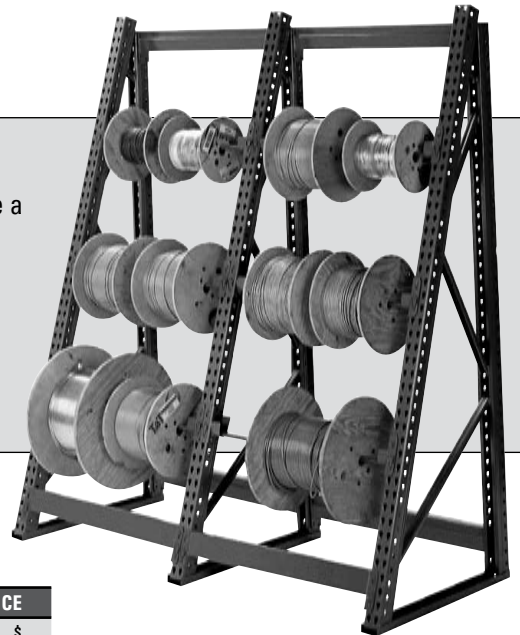

Extra Rods

SIZE	MODEL #	WEIGHT	PRICE
24" Bar	215-CR01024	3	\$
36" Bar	215-CR01036	4	
48" Bar	215-CR01048	5	

Extra Brackets

DESC.	MODEL #	WEIGHT	PRICE
Left Bracket	215-CRBL01	0.6	\$
Right Bracket	215-CRBR01	0.6	

Starter Units				Add-On Units		
W X D	MODEL #	WEIGHT	PRICE	MODEL #	WEIGHT	PRICE
3' HIGH UNITS						
24" x 18"	FRS-2418-036	49		FRT-2418-036	38	
36" x 18"	FRS-3618-036	55		FRT-3618-036	44	
48" x 18"	FRS-4818-036	74		FRT-4818-036	64	
8' HIGH UNITS						
24" x 24"	FRS-2424-096	74		FRT-2424-096	51	
36" x 24"	FRS-3624-096	80		FRT-3624-096	56	
48" x 24"	FRS-4824-096	100		FRT-4824-096	76	
24" x 36"	FRS-2436-096	80		FRT-2436-096	54	
36" x 36"	FRS-3636-096	86		FRT-3636-096	59	
48" x 36"	FRS-4836-096	106		FRT-4836-096	79	

Starter Units				Add-On Units		
W X D	MODEL #	WEIGHT	PRICE	MODEL #	WEIGHT	PRICE
6' HIGH UNITS						
24" x 24"	FRS-2424-072	68		FRT-2424-072	48	
36" x 24"	FRS-3624-072	73		FRT-3624-072	53	
48" x 24"	FRS-2436-072	93		FRT-4824-072	73	
10' HIGH UNITS						
24" x 24"	FRS-2424-120	82		FRT-2424-120	55	
36" x 24"	FRS-3624-120	88		FRT-3624-120	60	
48" x 24"	FRS-4824-120	107		FRT-4824-120	80	
24" x 36"	FRS-2436-120	87		FRT-2436-120	57	
36" x 36"	FRS-3636-120	93		FRT-3636-120	63	
48" x 36"	FRS-4836-120	113		FRT-4836-120	83	

STOCK RACKS

- Arms extend 8" from the frame.
- Pan Shelves are spaced 21" apart.
- Unit base is 36"W x 24"D.
- Unit is 84" high and has a capacity of 3,000 lbs.



Vertical Stock Rack

MODEL #	WEIGHT	PRICE
235-SRV1	80	\$

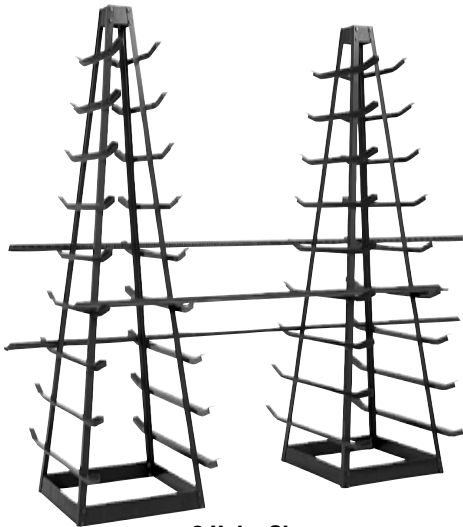

2 Units Shown

- Unit is 84" H x 22" square at the bottom.
- Unit tapers to 4 1/2" at the top.
- Angled steel arms are spaced every 8 1/2" and extend 8" from uprights.
- Capacity per pair of arms is 100 lbs.

Horizontal Stock Rack

MODEL #	WEIGHT	PRICE
235-SRH1	60	\$

FASTRAK TIRE STORAGE

- FastRak design makes these extra heavy duty units perfect for storing today's larger tires.
- Recommended for tires that accommodate 16" and larger rims.
- Units feature uprights that can be knocked down for easier shipment.



FastRak Tire Storage

W X D X H	# OF LEVELS	MODEL NUMBER	WT.	*PRICE
Starter Units				
48" x 18" x 96"	3	K33S-4818096	129	
72" x 18" x 96"	3	K33S-7218096	150	
96" x 18" x 96"	3	K33S-9618096	158	
48" x 18" x 120"	4	K34S-4818120	164	
72" x 18" x 120"	4	K34S-7218120	193	
96" x 18" x 120"	4	K34S-9618120	203	
Add-On Units				
48" x 18" x 96"	3	K33T-4818096	100	
72" x 18" x 96"	3	K33T-7218096	121	
96" x 18" x 96"	3	K33T-9618096	129	
48" x 18" x 120"	4	K34T-4818120	129	
72" x 18" x 120"	4	K34T-7218120	157	
96" x 18" x 120"	4	K34T-9618120	168	

*Units priced with unassembled uprights, please contact us for assembled upright pricing.

For additional safety, optional deluxe foot plates and concrete wedge anchors are available.



MODEL #	PRICE
DELUXE FOOT PLATES	
CUCF01	
CONCRETE WEDGE ANCHOR	
235-FA01	

BIN STORAGE UNITS COMPLETE W/ BINS

- Units available with 12" or 18" deep bins.
- Corrugated bins are constructed of 200 lb. test corrugated board.
- Plastic bins are waterproof (unaffected by grease or oil).
- Units available with or without particle board decking.



Corrugated Bin Units			w/ Particle Board Decking			w/o Particle Board Decking		
SHELVING W X D X H	BIN W X D X H	# OF BINS	MODEL NUMBER	WT.	PRICE	MODEL NUMBER	WT.	PRICE
36" x 12" x 36"	4" x 12" x 4"	40	A6-3612-36W-CB4	75		A6-3612-36-CB4	36	
36" x 12" x 36"	6" x 12" x 4"	25	A6-3612-36W-CB6	74		A6-3612-36-CB6	34	
36" x 12" x 36"	8" x 12" x 4"	20	A6-3612-36W-CB8	73		A6-3612-36-CB8	34	
36" x 18" x 36"	4" x 18" x 4"	40	A6-3618-36W-CB4	98		A6-3618-36-CB4	39	
36" x 18" x 36"	6" x 18" x 4"	25	A6-3618-36W-CB6	96		A6-3618-36-CB6	37	
36" x 12" x 72"	4" x 12" x 4"	88	A12-3612-72W-CB4	132		A12-3612-72-CB4	53	
36" x 12" x 72"	6" x 12" x 4"	55	A12-3612-72W-CB6	128		A12-3612-72-CB6	49	
36" x 12" x 72"	8" x 12" x 4"	44	A12-3612-72W-CB8	128		A12-3612-72-CB8	49	
36" x 18" x 72"	4" x 18" x 4"	88	A12-3618-72W-CB4	130		A12-3618-72-CB4	51	
36" x 18" x 72"	6" x 18" x 4"	55	A12-3618-72W-CB6	177		A12-3618-72-CB6	58	
36" x 12" x 72"	4" x 12" x 4"	40	A12-3612-72W-CBC	173		A12-3612-72-CBC	54	
	6" x 12" x 4"	30						
36" x 18" x 72"	4" x 18" x 4"	40	A12-3618-72W-CBC	174		A12-3618-72-CBC	56	
	6" x 18" x 4"	30						

Plastic Bin Units			w/ Particle Board Decking			w/o Particle Board Decking		
SHELVING W X D X H	BIN W X D X H	# OF BINS	MODEL NUMBER	WT.	PRICE	MODEL NUMBER	WT.	PRICE
36" x 12" x 36"	4" x 11 ¹ / ₂ " x 4"	40	A6-3612-36W-SB4	89		A6-3612-36-SB4	50	
36" x 12" x 36"	6" x 11 ¹ / ₂ " x 4"	25	A6-3612-36W-SB6	84		A6-3612-36-SB6	45	
36" x 12" x 36"	8" x 11 ¹ / ₂ " x 4"	20	A6-3612-36W-SB8	83		A6-3612-36-SB8	44	
36" x 18" x 36"	4" x 17 ¹ / ₂ " x 4"	40	A6-3618-36W-SB4	114		A6-3618-36-SB4	55	
36" x 18" x 36"	6" x 17 ¹ / ₂ " x 4"	25	A6-3618-36W-SB6	110		A6-3618-36-SB6	51	
36" x 12" x 72"	4" x 11 ¹ / ₂ " x 4"	88	A12-3612-72W-SB4	177		A12-3612-72-SB4	98	
36" x 12" x 72"	6" x 11 ¹ / ₂ " x 4"	55	A12-3612-72W-SB6	166		A12-3612-72-SB6	87	
36" x 12" x 72"	8" x 11 ¹ / ₂ " x 4"	44	A12-3612-72W-SB8	164		A12-3612-72-SB8	84	
36" x 18" x 72"	4" x 17 ¹ / ₂ " x 4"	88	A12-3618-72W-SB4	226		A12-3618-72-SB4	108	
36" x 18" x 72"	6" x 17 ¹ / ₂ " x 4"	55	A12-3618-72W-SB6	218		A12-3618-72-SB6	99	
36" x 12" x 72"	4" x 11 ¹ / ₂ " x 4"	40	A12-3612-72W-SBC	171		A12-3612-72-SBC	92	
	6" x 11 ¹ / ₂ " x 4"	30						
36" x 18" x 72"	4" x 17 ¹ / ₂ " x 4"	40	A12-3618-72W-SBC	222		A12-3618-72-SBC	103	
	6" x 17 ¹ / ₂ " x 4"	30						

PICK RACKS

- Features angled shelves for easy visibility and quick access to parts and supplies.
- Units are 12" deep and are available with either 4", 6" or 8" wide bins.
- Bench Rack dimensions: 34"W x 12"D x 23"H
- Floor Rack dimensions: 34"W x 12"D x 61"H

Plastic Bin Units				Corrugated Bin Units			
BIN SIZE W X D X H	# OF BINS	MODEL NUMBER	WEIGHT	PRICE	MODEL NUMBER	WEIGHT	PRICE
Bench Rack							
4" x 11 ¹ / ₂ " x 4"	24	PRB-SB4	30		PRB-CB4	30	
6" x 11 ¹ / ₂ " x 4"	15	PRB-SB6	29		PRB-CB6	29	
8" x 11 ¹ / ₂ " x 4"	12	PRB-SB8	28		PRB-CB8	28	
Rack Only	N/A	235-PRB1	21		235-PRB1	21	
Floor Rack							
4" x 11 ¹ / ₂ " x 4"	64	PRF-SB4	71		PRF-CB4	71	
6" x 11 ¹ / ₂ " x 4"	40	PRF-SB6	67		PRF-CB6	67	
8" x 11 ¹ / ₂ " x 4"	32	PRF-SB8	65		PRF-CB8	65	
Rack Only	N/A	235-PRF1	47		235-PRF1	47	

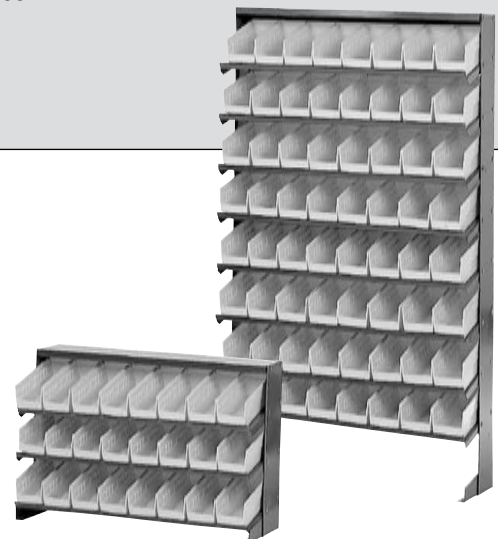

MOBILE SHELVING WITH PLASTIC OR CORRUGATED BINS

- Complete with either plastic or corrugated shelf bins.
- Available in either single or double sided units.
- Allows easy transport of bins in work areas.
- Heavy duty mobile shelf carts.

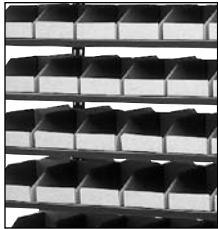

Available with Corrugated Bins

Plastic Bin Units

Corrugated Bin Units

CART W X D X H	BIN SIZE W X D X H	# OF BINS	MODEL NUMBER	WEIGHT	PRICE	# OF BINS	MODEL NUMBER	WEIGHT	PRICE
SINGLE SIDED UNITS									
48" x 12" x 37"	4" x 12" x 4"	44	CA5-4812-30W-S4	103		88	CA5-4812-30W-C4	95	
48" x 12" x 37"	6" x 12" x 4"	28	CA5-4812-30W-S6	100		56	CA5-4812-30W-C6	93	
48" x 12" x 37"	8" x 12" x 4"	20	CA5-4812-30W-S8	99		40	CA5-4812-30W-C8	92	
48" x 18" x 37"	4" x 18" x 4"	44	CA5-4818-30W-S4	134		88	CA5-4818-30W-C4	121	
48" x 18" x 37"	6" x 18" x 4"	28	CA5-4818-30W-S6	131		56	CA5-4818-30W-C6	119	
48" x 24" x 37"	4" x 12" x 4"	88	CA5-4824-30W-S4	167		176	CA5-4824-30W-C4	151	
48" x 24" x 37"	6" x 12" x 4"	56	CA5-4824-30W-S6	160		112	CA5-4824-30W-C6	147	
48" x 24" x 37"	8" x 12" x 4"	40	CA5-4824-30W-S8	158		80	CA5-4824-30W-C8	145	
48" x 36" x 37"	4" x 18" x 4"	88	CA5-4836-30W-S4	230		176	CA5-4836-30W-C4	204	
48" x 36" x 37"	6" x 18" x 4"	56	CA5-4836-30W-S6	224		112	CA5-4836-30W-C6	200	
DOUBLE SIDED UNITS									
48" x 12" x 67"	4" x 12" x 4"	88	CA9-4812-60W-S4	174		88	CA9-4812-60W-C4	158	
48" x 12" x 67"	6" x 12" x 4"	56	CA9-4812-60W-S6	168		56	CA9-4812-60W-C6	154	
48" x 12" x 67"	8" x 12" x 4"	40	CA9-4812-60W-S8	165		40	CA9-4812-60W-C8	153	
48" x 18" x 67"	4" x 18" x 4"	88	CA9-4818-60W-S4	230		88	CA9-4836-60W-C4	203	
48" x 18" x 67"	6" x 18" x 4"	56	CA9-4818-60W-S6	224		56	CA9-4836-60W-C6	199	
48" x 24" x 67"	4" x 12" x 4"	176	CA9-4824-60W-S4	288		176	CA9-4824-60W-C4	257	
48" x 24" x 67"	6" x 12" x 4"	112	CA9-4824-60W-S6	276		112	CA9-4824-60W-C6	249	
48" x 24" x 67"	8" x 12" x 4"	80	CA9-4824-60W-S8	271		80	CA9-4824-60W-C8	246	
48" x 36" x 67"	4" x 18" x 4"	176	CA9-4836-60W-S4	401		176	CA9-4836-60W-C4	348	
48" x 36" x 67"	6" x 18" x 4"	112	CA9-4836-60W-S6	388		112	CA9-4836-60W-C6	340	

INDIVIDUAL CORRUGATED BINS

- Economical way to store and organize small or loose parts.
- Bins are constructed of 200 lb. test corrugated board.
- Sold 100 bins per carton only.



MODEL #	BIN SIZE W X D X H	WT.	PRICE
225-BC124	4" x 12" x 4"	.17	
225-BC126	6" x 12" x 4"	.20	
225-BC128	8" x 12" x 4"	.24	
225-BC184	4" x 18" x 4"	.21	
225-BC186	6" x 18" x 4"	.26	

INDIVIDUAL PLASTIC BINS

- Available in 11^{1/2}" and 17^{1/2}" depths.
- Add bin dividers to separate small parts.
- Durable polypropylene.
- Bins are waterproof (unaffected by grease or oil).



Plastic Bins

MODEL #	BIN SIZE W X D X H	WT.	CTN. QTY.	PRICE
225-SB124	4" x 11 ^{1/2} " x 4"	.40	24	
225-SB126	6" x 11 ^{1/2} " x 4"	.50	24	
225-SB128	8" x 11 ^{1/2} " x 4"	.60	24	
225-SB184	4" x 17 ^{1/2} " x 4"	.60	24	
225-SB186	6" x 17 ^{1/2} " x 4"	.70	24	

Bin Dividers

MODEL #	FOR BIN WIDTH	WT.	CTN. QTY.	PRICE
225-SBD4	4"	.10	24	
225-SBD6	6"	.10	24	
225-SBD8	8"	.10	24	

Bin Cups

MODEL #	OUTSIDE W X D X H	WT.	CTN. QTY.	PRICE
225-SBC1	3 ^{1/4} " x 1 ^{7/8} " x 3"	.10	100	

* Sold in Carton Quantities Only

JUMBO BIN STORAGE UNITS

- Units come complete with polypropylene jumbo bins.
- A cost efficient way to store small, medium and large parts.
- Heavy duty industrial boltless design.
- Boltless design provides for quick, easy assembly and years of dependable service.



Mobile Units

Series 200A Unit

Series 200B Unit

Mobile Units with Bins

W X D X H	# OF BINS	# OF SHELVES	MODEL NUMBER	WT.	PRICE
48" x 18" x 67"	16	5	QM2-(B/Y/R)260	176	
60" x 18" x 67"	20	5	QM3-(B/Y/R)260	227	
48" x 36" x 67"	32	5	QM7-(B/Y/R)260	318	
60" x 36" x 67"	40	5	QM8-(B/Y/R)260	402	

Series 200A Units with Bins

W X D X H	# OF BINS	# OF SHELVES	MODEL NUMBER	WT.	PRICE
36" x 18" x 36"	6	3	QK1-(B/Y/R)260	77	
48" x 18" x 36"	8	3	QK2-(B/Y/R)260	99	
36" x 18" x 72"	15	6	QL1-(B/Y/R)260	160	
48" x 18" x 72"	20	6	QL2-(B/Y/R)260	207	

Series 200B Units with Bins

W X D X H	# OF BINS	# OF SHELVES	MODEL NUMBER	WT.	PRICE
36" x 18" x 72"	12	5	QP1-(B/Y/R)260	144	
48" x 18" x 72"	16	5	QP2-(B/Y/R)260	184	
60" x 18" x 72"	20	5	QP3-(B/Y/R)260	232	
72" x 18" x 72"	24	5	QP4-(B/Y/R)260	275	
96" x 18" x 72"	32	5	QP5-(B/Y/R)260	358	

FREE-STANDING BIN STORAGE UNITS

- Provides quick and easy access to small and medium parts.
- Bins can be easily removed from storage units.
- Durable polypropylene bins are virtually crack and chip proof.
- Ideal for use in assembly / production areas.
- Easy to assemble and no special tools required.
- 750 lbs. total unit capacity.
- Units come complete with bins.

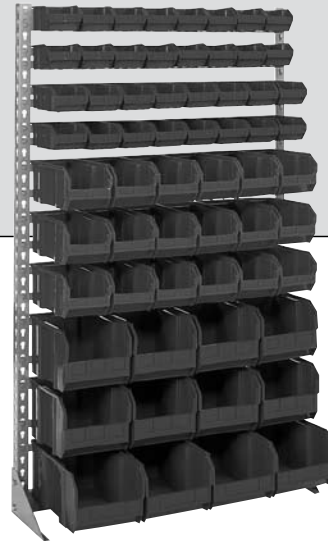

Bench Rack

BIN D X W X H	# OF ROWS	BINS / ROW	# OF BINS	MODEL NUMBER	WT.	PRICE
5 ³ / ₈ " x 4 ¹ / ₈ " x 3"	5	8	40	QE(B/Y/R)210	24	
7 ³ / ₈ " x 4 ¹ / ₈ " x 3"	5	8	40	QE(B/Y/R)220	25	
10 ¹ / ₈ " x 5 ¹ / ₂ " x 5"	4	6	24	QE(B/Y/R)230	33	
10 ¹ / ₈ " x 11" x 5"	4	3	12	QE(B/Y/R)235	29	
10 ³ / ₄ " x 8 ¹ / ₄ " x 7"	3	4	12	QE(B/Y/R)239	30	
5 ³ / ₈ " x 4 ¹ / ₈ " x 3"	1	8	8	QE(B/Y/R)C1 4 total rows	28	
7 ³ / ₈ " x 4 ¹ / ₈ " x 3"	1	8	8			
10 ⁷ / ₈ " x 5 ¹ / ₂ " x 5"	2	6	12			

Single Sided Floor Rack

BIN D X W X H	# OF ROWS	BINS / ROW	# OF BINS	MODEL NUMBER	WT.	PRICE
5 ³ / ₈ " x 4 ¹ / ₈ " x 3"	12	8	96	QF(B/Y/R)210	49	
7 ³ / ₈ " x 4 ¹ / ₈ " x 3"	12	8	96	QF(B/Y/R)220	53	
10 ⁷ / ₈ " x 5 ¹ / ₂ " x 5"	9	6	54	QF(B/Y/R)230	69	
10 ⁷ / ₈ " x 11" x 5"	9	3	27	QF(B/Y/R)235	60	
10 ³ / ₄ " x 8 ¹ / ₄ " x 7"	7	4	28	QF(B/Y/R)239	63	
14 ³ / ₄ " x 8 ¹ / ₂ " x 7"	7	4	28	QF(B/Y/R)240	83	
14 ³ / ₄ " x 16 ¹ / ₂ " x 7"	7	2	14	QF(B/Y/R)250	71	
5 ³ / ₈ " x 4 ¹ / ₈ " x 3"	2	8	16	QF(B/Y/R)C1 10 total rows	72	
7 ³ / ₈ " x 4 ¹ / ₈ " x 3"	2	8	16			
10 ⁷ / ₈ " x 5 ¹ / ₂ " x 5"	3	6	18			
10 ³ / ₄ " x 8 ¹ / ₄ " x 7"	2	4	8			
14 ³ / ₄ " x 8 ¹ / ₂ " x 7"	1	4	4			

STACKABLE BINS

- Stackable bins are made of heavy duty polypropylene with permanent molded-in color.
- Bins are virtually unbreakable and are water, rust and corrosion-proof.
- Finger grips are provided for ease of handling.
- Bins have reinforced ribs to prevent them from spreading under load.
- Bins have large slotted label area.
- Choose from 9 different sizes and 3 different colors.
- Bins are locally stocked and offer quick shipment.

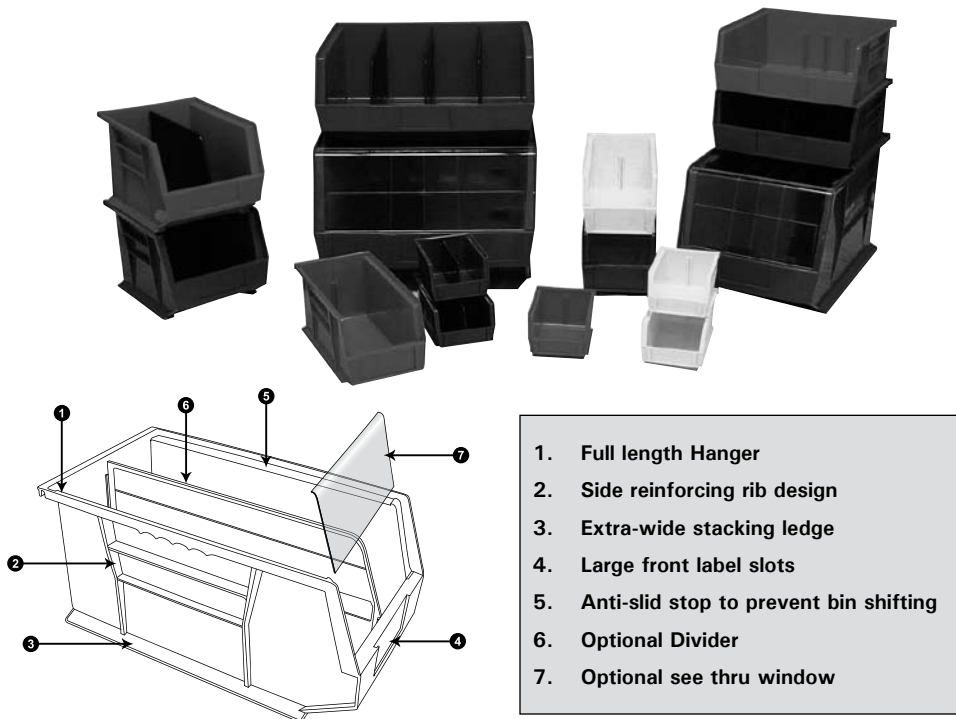

1. Full length Hanger
2. Side reinforcing rib design
3. Extra-wide stacking ledge
4. Large front label slots
5. Anti-slid stop to prevent bin shifting
6. Optional Divider
7. Optional see thru window

Stackable Bins

OUTSIDE D X W X H	*CARTON QTY.	BLUE BINS	YELLOW BINS	RED BINS	WEIGHT	*PRICE
5 ³ / ₈ " x 4 ¹ / ₈ " x 3"	24	225-QTB210	225-QTY210	225-QTR210	.20	\$ ea.
7 ³ / ₈ " x 4 ¹ / ₈ " x 3"	24	225-QTB220	225-QTY220	225-QTR220	.25	ea.
10 ⁷ / ₈ " x 5 ¹ / ₂ " x 5"	12	225-QTB230	225-QTY230	225-QTR230	.70	ea.
10 ⁷ / ₈ " x 11" x 5"	6	225-QTB235	225-QTY235	225-QTR235	1.10	ea.
10 ³ / ₄ " x 8 ¹ / ₄ " x 7"	6	225-QTB239	225-QTY239	225-QTR239	1.15	ea.
14 ³ / ₄ " x 8 ¹ / ₂ " x 7"	12	225-QTB240	225-QTY240	225-QTR240	1.90	ea.
14 ³ / ₄ " x 16 ¹ / ₂ " x 7"	6	225-QTB250	225-QTY250	225-QTR250	2.90	ea.
18" x 11" x 10"	4	225-QTB260	225-QTY260	225-QTR260	4.25	ea.
18" x 16 ¹ / ₂ " x 11"	3	225-QTB270	225-QTY270	225-QTR270	5.35	ea.

Clear Plastic Windows

Bin Dividers

FITS BIN SIZE	MODEL NUMBER	*CARTON QTY.	PRICE	MODEL NUMBER	*CARTON QTY.	*PRICE
5 ³ / ₈ " x 4 ¹ / ₈ " x 3"	N/A	N/A	N/A	225-QTAD210	6	\$ ea.
7 ³ / ₈ " x 4 ¹ / ₈ " x 3"	N/A	N/A	N/A	225-QTAD220	6	ea.
10 ⁷ / ₈ " x 5 ¹ / ₂ " x 5"	225-QTAW230	12	\$ ea.	225-QTAD230	6	ea.
10 ⁷ / ₈ " x 11" x 5"	225-QTAW235	6	ea.	225-QTAD235	6	ea.
10 ³ / ₄ " x 8 ¹ / ₄ " x 7"	225-QTAW239	6	ea.	225-QTAD239	6	ea.
14 ³ / ₄ " x 8 ¹ / ₂ " x 7"	225-QTAW240	12	ea.	225-QTAD240	6	ea.
14 ³ / ₄ " x 16 ¹ / ₂ " x 7"	225-QTAW250	6	ea.	225-QTAD250	6	ea.
18" x 11" x 10"	225-QTAW260	4	ea.	225-QTAD260	6	ea.
18" x 16 ¹ / ₂ " x 11"	225-QTAW270	3	ea.	225-QTAD270	6	ea.

* Sold in Carton Quantities Only



FASTRAK ARCHIVE STORAGE UNITS

- Built to hold even your heaviest archive boxes.
- Featuring our heavy duty FastRak uprights that can be knocked down for easier shipment.
- Each level will hold a full 1,600 lbs.
- Units can accommodate either 12" or 24" deep archive boxes.
- Single deep or double deep units are available.
- Optional foot plates available (see page 4).

Starter Units

Add-On Units

W X D X H	# OF LEVELS	BOX CAP.	MODEL NUMBER	WT.	*PRICE	MODEL NUMBER	WT.	*PRICE	MODEL NUMBER	WT.	*PRICE	MODEL NUMBER	WT.	*PRICE
			WITHOUT BOXES			WITH BOXES			WITHOUT BOXES			WITH BOXES		
96" x 18" x 96"	4	56	K34S-9618096W	326		K34S-9618096WS	405		K34T-9618096W	297		K34T-9618096WS	376	
96" x 24" x 96"	4	56	K34S-9624096W	408		K34S-9624096WS	543		K34T-9624096W	377		K34T-9624096WS	512	
96" x 36" x 96"	4	112	K34S-9636096W	510		K34S-9636096WS	667		K34T-9636096W	476		K34T-9636096WS	633	
96" x 48" x 96"	4	112	K34S-9648096W	612		K34S-9648096WS	880		K34T-9648096W	575		K34T-9648096WS	844	
96" x 18" x 120"	5	70	K35S-9618120W	338		K35S-9618120WS	436		K35T-9618120W	303		K35S-9618120WS	401	
96" x 24" x 120"	5	70	K35S-9624120W	421		K35S-9624120WS	589		K35T-9624120W	384		K35S-9624120WS	552	
96" x 36" x 120"	5	140	K35S-9636120W	526		K35S-9636120WS	722		K35T-9636120W	484		K35S-9636120WS	680	
96" x 48" x 120"	5	140	K35S-9648120W	632		K35S-9648120WS	968		K35T-9648120W	585		K35S-9648120WS	921	

*Units priced with unassembled uprights, please contact us for assembled upright pricing.

RECORD ARCHIVE SHELVING

- High Capacity Boltless Shelving.
- Available with or without archive storage boxes.
- Accommodates 15" or 24" deep boxes.
- Easy to assemble.



Series 200A



Series 200B

INDIVIDUAL BOXES

- These rugged 200 lb. corrugated boxes are ideal for storing documents.
- Handles provide added strength and durability
- Tight fitting lids adds rigidity.
- Sold 10 boxes per bundle.

W X H	BOX CAP.	BOX DEPTH	with Particle Board			without Particle Board		
			MODEL NUMBER	WT.	PRICE	MODEL NUMBER	WT.	PRICE
ARCHIVE SHELVING FOR 15" DEEP ARCHIVE BOXES								
42" x 60"	15	Single	A5-4215-60W	89	118.27	A5-4215-60	34	
42" x 60"	21	Single	A7-4215-84W	123	158.61	A7-4215-84	46	
ARCHIVE SHELVING FOR 24" DEEP ARCHIVE BOXES								
42" x 60"	15	Single	A5-4224-60W	113	93.21	A5-4224-60	36	
42" x 84"	21	Single	A7-4224-84W	155	140.88	A7-4224-84	47	

W X H	BOX CAP.	BOX DEPTH	with Particle Board			without Particle Board		
			MODEL NUMBER	WT.	PRICE	MODEL NUMBER	WT.	PRICE
ARCHIVE SHELVING FOR 15" DEEP ARCHIVE BOXES								
69" x 60"	30	Single	B3-6915-60W	94	139.76	B3-6915-60	47	110.68
69" x 84"	40	Single	B4-6915-84W	126	188.36	B4-6915-84	63	149.60
69" x 108"	50	Single	B5-6915-108W	153	237.08	B5-6915-108	74	188.68
42" x 60"	36	Double	B3-4230-60WH	99	144.07	B3-4230-60H	41	108.70
42" x 84"	48	Double	B4-4230-84WH	132	194.13	B4-4230-84H	55	146.96
69" x 60"	60	Double	B3-6930-60WH	151	196.12	B3-6930-60H	61	137.98
69" x 84"	80	Double	B4-6930-84WH	182	263.52	B4-6930-84H	76	186.00
69" x 108"	100	Double	B5-6930-108WH	253	331.02	B5-6930-108H	95	234.12
ARCHIVE SHELVING FOR 24" DEEP ARCHIVE BOXES								
69" x 60"	30	Single	B3-6924-60W	125	163.80	B3-6924-60	50	117.31
69" x 84"	40	Single	B4-6924-84W	167	220.44	B4-6924-84	67	158.45
69" x 108"	50	Single	B5-6924-108W	209	277.19	B5-6924-108	84	199.69
69" x 60"	36	Double	B3-6948-60WH	201	252.16	B3-6948-60H	66	159.16
69" x 84"	48	Double	B4-6948-84WH	268	338.25	B4-6948-84H	88	214.25
69" x 108"	100	Double	B5-6948-108WH	335	424.43	B5-6948-108H	110	269.43



225-SF1



225-SF2

MODEL	D X W X H	WT.	PRICE
15" DEEP ARCHIVE BOXES			
225-SF1	15" x 12" x 11"	1.4	\$
24" DEEP ARCHIVE BOXES			
225-SF2	24" x 12" x 11"	2.4	\$

ECONOMY SERVICE CARTS

- Constructed of heavy gauge steel.
- Top tray can be reversed to provide platform top .
- Trays are 3^{3/8}" deep.
- Includes 2 swivel and 2 rigid locking polypropylene casters.
- Durable Gray powder coated finish.
- 400 lb. capacity.
- Unit ships Knocked Down



SHELF SIZE	MODEL NUMBER	WT.	PRICE
2 SHELF CART			
16" x 30"	220-CSK1630	38	\$

STEEL SERVICE CARTS

- These heavy duty carts feature 100% steel construction.
- Carts are completely set up and welded for years of rugged service.
- Heavy duty ball-bearing casters with 5" or 6" rubber wheels.
- Cart capacity with 5" casters: 600 lbs. Cart capacity with 6" casters: 1,000 lbs.



Tray Shelves				Deck Shelves		
L X W X H	MODEL #	WT.	PRICE	MODEL #	WT.	PRICE
5" RUBBER WHEELS						
16" x 30" x 34"	220-CST1630	50	\$187.00	220-CSD1630	46	\$
24" x 36" x 34"	220-CST2436	73	231.41	220-CSD2436	69	
24" x 48" x 34"	220-CST2448	88	252.23	220-CSD2448	83	
6" RUBBER WHEELS						
16" x 30" x 34"	220-CSTH1630	76	\$240.07	220-CSDH1630	76	\$
24" x 36" x 34"	220-CSTH2436	102	284.48	220-CSDH2436	94	
24" x 48" x 34"	220-CSTH2448	112	305.31	220-CSDH2448	108	

PLASTIC SERVICE CARTS

- Constructed of durable plastic for years of service.
- Plastic cart won't rust and is less conductive than metal service carts making them ideal for use with electronic equipment.
- Carts come with 2 swivel and 2 rigid 5" rubber caster wheels.
- 300 lb. capacity.



SHELF SIZE	MODEL #	WT.	PRICE
2 SHELF CART			
16" x 30"	220-CSP1630	40	\$
24" x 36"	220-CSP2436	51	
3 SHELF CART			
16" x 30"	MCSP1630	52	\$
24" x 36"	MCSP2436	79	

**PLATFORM TRUCK
W/FOLD-DOWN HANDLE**

- Versatile platform truck features a fold-down handle for easy storage.
- Ideal for transporting boxes and light equipment around office and warehouse.
- Plastic bumpers protect walls, furniture and doorways.
- Cart capacity:
300 lbs. (220-PFD1)
500 lbs. (220-PFD2)



MODEL NUMBER	CASTER SIZE	WT.	PRICE
220-PFD1	17" x 27"	24	\$
220-PFD2	22" x 34"	47	

HEAVY DUTY PLATFORM TRUCKS

- Constructed of heavy gauge steel and is all welded to provide years of service.
- Available with either 5", 6" or 8" casters.
- 2 swivel and 2 rigid casters.
- Features a removable handle with two handle cross braces.
- High capacity.



MODEL #	CASTER SIZE	CAP.	WT.	PRICE
PR2448	5"	800	74	
PR2754	5"	800	85	
PR3060	5"	800	99	
PR3672	5"	800	132	
PS2448	6"	1,600	77	
PS2754	6"	1,600	88	
PS3060	6"	1,600	102	
PS3672	6"	1,600	135	
PW2448	8"	2,000	81	
PW2754	8"	2,000	92	
PW3060	8"	2,000	106	
PW3672	8"	2,000	139	

DURABLE PLASTIC PLATFORM TRUCK

- Durable plastic deck will not rust or dent.
- Available with 4 (2 swivel and 2 rigid) or 6 (4 swivel and 2 rigid) casters.
- Trucks are available with either 1 or 2 handles.
- Choose between 6" or 8" casters.
- Cart capacity with 6" wheels: 800 lbs.
- Cart capacity with 8" casters: 1,200 lbs.



SIZE	# OF CASTERS	6" Caster Wheels			8" Caster Wheels		
		MODEL NUMBER	WT.	PRICE	MODEL NUMBER	WT.	PRICE
1 HANDLE UNIT							
59.5" x 29.5"	4	PPT3060-A16	125		PPT3060-A18	137	572.61
59.5" x 29.5"	6	PPT3060-B16	134		PPT3060-B18	151	621.52
2 HANDLE UNIT							
59.5" x 29.5"	4	PPT3060-A26	135		PPT3060-A28	146	619.87
59.5" x 29.5"	6	PPT3060-B26	143		PPT3060-B28	161	668.78

MOBILE SHELF CARTS

- 2 rigid and 2 swivel wheels included.
- Capacity 700 lbs. per cart.
- 5" industrial wheels with ball bearings.
- Available with or without particle board.



Advanced Boltless Design



with Particle Board				without Particle Board			with Particle Board			without Particle Board		
SHELF SIZE	MODEL NUMBER	WT.	PRICE	MODEL NUMBER	WT.	PRICE	MODEL NUMBER	WT.	PRICE	MODEL NUMBER	WT.	PRICE
3 SHELF MOBILE UNIT						4 SHELF MOBILE UNIT						
36" x 24"	BC3-3624-60W	87		BC3-3624-60	47		BC4-3624-60W	106		BC4-3624-60	54	
48" x 12"	BC3-4812-60W	72		BC3-4812-60	47		BC4-4812-60W	88		BC4-4812-60	52	
48" x 18"	BC3-4818-60W	88		BC3-4818-60	48		BC4-4818-60W	108		BC4-4818-60	55	
48" x 24"	BC3-4824-60W	104		BC3-4824-60	51		BC4-4824-60W	130		BC4-4824-60	59	
48" x 36"	BC3-4836-60W	137		BC3-4836-60	58		BC4-4836-60W	173		BC4-4836-60	67	
60" x 24"	BC3-6024-60W	125		BC3-6024-60	59		BC4-6024-60W	158		BC4-6024-60	70	
60" x 30"	BC3-6030-60W	145		BC3-6030-60	62		BC4-6030-60W	184		BC4-6030-60	74	
60" x 36"	BC3-6036-60W	164		BC3-6036-60	65		BC4-6036-60W	210		BC4-6036-60	78	

TERMS & CONDITIONS

Terms:
 Net 30 days (OAC), Prepaid or COD. Past due accounts are subject to finance charges of 1¹/₂% per month (18% annually) and/or collection charges.

Damaged Items:
 For your protection, should visual inspection upon receipt of any merchandise reveal loss or damage, it must be noted on the freight bill and signed by the carrier's agent. Call 1-800-401-7225 immediately to speak to a Jaken representative and initiate a freight claim.

Prices:
 Prices are subject to change without notice. Prices shown in catalog are list.

Minimum Order:
 Order of \$120 list.

Returns:
 Returns accepted on new and unused items only. No returns will be accepted without Jaken's prior permission and a Return of Goods Authorization Number (RGA#). All returns must be shipped freight prepaid to Jaken's Distribution Center in La Palma, California. Returns on new and unused merchandise will be subject to a 15% restocking charge or a minimum of \$20.00.



Pallet Rack



FastRak Bulk Shelving

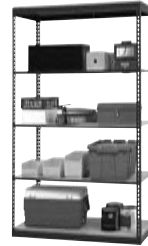

Boltless Shelving

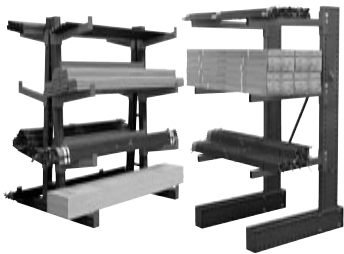
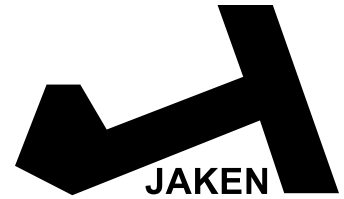

Cantilever Rack



Wire Shelving



Archive Shelving



Carts & Trucks



Bins & Boxes



Workbenches & Packing Tables



Stock, Reel & Tire Racks

Distributed By: